

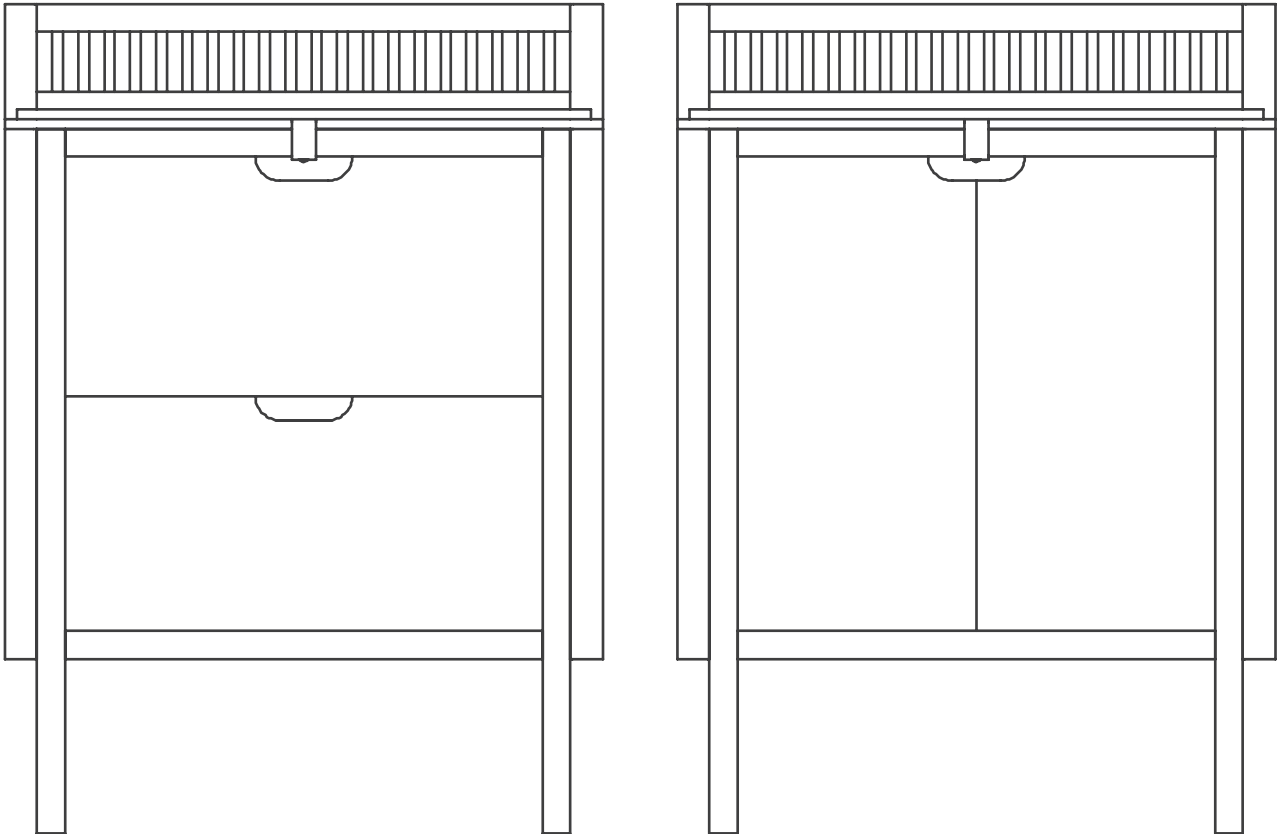

ASSEMBLY INSTRUCTION



SAMLEVEJLEDNING | BAUANLEITUNG | INSTRUCTIONS DE MONTAGE | INSTRUCCIONES DE ARMADO | ISTRUZIONI DI MONTAGGIO | MONTAGEHANDLEIDING

IMPORTANT, RETAIN FOR FUTURE REFERENCE: READ CAREFULLY
VIGTIGT - GEM TIL SENERE BRUG - LÆS OMHYGGELIGT
WICHTIG, FÜR SPÄTERE VERWENDUNG AUFBEWAHREN: SORGFÄLTIG LESEN
IMPORTANT. A CONSERVER POUR CONSULTATION ULTÉRIEURE. A LIRE SOIGNEUSEMENT.
IMPORTANTE. CONSERVAR PARA FUTURAS CONSULTAS. LEER CUIDADOSAMENTE.
IMPORTANTE - CONSERVARE IN CASO DI NECESSITÀ FUTURA - LEGGERE ATTENTAMENTE.
BELANGRIJK - BEWAREN VOOR LATER GEBRUIK - ZORGVULDIG DOORLEZEN.

UK

Thank you for purchasing this product from Sebra. For safety reasons, you should read the assembly instructions carefully before assembling the product.

Check the contents of the package before the product is assembled. A complete summary of the contents of the package can be found on the following pages. In the unlikely event you are missing something, please contact the dealer who sold you the product.

This product takes about 30-45 MINUTES to assemble.

IT REQUIRES 2 PEOPLE to assemble the bed
THIS PACKAGE CONTAINS SMALL PARTS, that MUST BE KEPT AWAY FROM SMALL CHILDREN.

DK

Tak, fordi du har købt dette produkt fra Sebra. Af sikkerhedsmæssige grunde bør du læse samlevvejledningen grundigt, før du samler dette produkt.

Kontrollér indholdet af emballagen, før produktet samles. En komplet oversigt over emballagens indhold kan findes på de følgende sider. Hvis du mod forventning mangler noget, skal du kontakte den forhandler, der har solgt dig produktet.

Dette produkt tager ca. 30-45 MINUTTER at samle.

DET KRÆVER 2 PERSONER at samle sengen
DENNE EMBALLAGE INDEHOLDER SMÅ DELE, som SKAL HOLDES VÆK FRA SMÅ BØRN.

DE

Vielen Dank, dass Sie sich für dieses Produkt von Sebra entschieden haben. Aus Sicherheitsgründen sollten Sie die Montageanleitung sorgfältig durchlesen, bevor Sie das Produkt montieren.

Überprüfen Sie den Inhalt des Pakets, bevor das Produkt montiert wird. Auf den folgenden Seiten finden Sie eine vollständige Übersicht des Paketinhalts. Wenn wider Erwarten etwas fehlen sollte, bitten wir Sie, den Händler zu kontaktieren, der Ihnen das Produkt verkauft hat.

Dieses Produkt dauert etwa 30-45 Minuten zu montieren.

Das Bett sollte zu zweit montiert werden.
Diese Verpackung enthält Kleinteile, die von Kleinkindern fern gehalten werden müssen.

FR

Nous vous remercions d'avoir acheté ce produit Sebra. Pour des raisons de sécurité, vous devez lire les instructions de montage avant de monter le produit.

Pour des raisons de sécurité, veuillez lire attentivement ces instructions avant de monter le lit. Veuillez vérifier le contenu du paquet avant de monter le lit. Vous trouverez une liste de vérification complète aux pages suivantes. Si, contre toute attente, il manquait un élément, veuillez contacter le revendeur chez qui vous avez acheté ce meuble.

Il faut environ 30-45 MINUTES pour monter ce lit.

DEUX PERSONNES SONT NÉCESSAIRES pour monter ce lit.
CE PAQUET CONTIENT DES PETITES PIÈCES devant ÊTRE TENUES HORS DE PORTÉE DES ENFANTS.

ES

Gracias por comprar este producto de Sebra. Por razones de seguridad, debe leer las instrucciones de montaje detenidamente antes de montar el producto.

Antes de armar este producto verifique el contenido del paquete. En las siguientes páginas se puede encontrar una lista de verificación completa de los componentes. Si faltara algún componente, póngase en contacto con el establecimiento donde se adquirió el producto.

Este producto insume aproximadamente 30-45 MINUTOS para ser armado.

SE REQUIEREN 2 PERSONAS para armar la cuna.
ESTE PAQUETE CONTIENE PIEZAS PEQUEÑAS que DEBERÁN MANTENERSE FUERA DEL ALCANCE DE LOS NIÑOS PEQUEÑOS.

IT

Grazie per aver acquistato questo prodotto Sebra. Per motivi di sicurezza, prima di procedere al montaggio del prodotto si consiglia di leggere con attenzione le istruzioni in merito.

Verificare il contenuto della confezione prima di montare questo prodotto. Una panoramica completa del contenuto della confezione è presente nelle pagine seguenti. In caso alcuni componenti risultassero mancanti, contattare il punto vendita presso il quale il prodotto è stato acquistato.

Il montaggio di questo prodotto richiede circa 30-45 MINUTI.

SONO NECESSARIE 2 PERSONE per montare il letto.
LA CONFEZIONE CONTIENE PICCOLI ELEMENTI che vanno TENUTI FUORI DALLA PORTATA DEI BAMBINI PICCOLI.

NL

Dank u voor de aankoop van dit product van Sebra. Om veiligheidsredenen moet u de montage-instructies zorgvuldig doorlezen alvorens het product te monteren.

Controleer de inhoud van het pakket, voordat u dit product in elkaar zet. Op de volgende pagina's vindt u een compleet overzicht van de inhoud van dit pakket. Mochten er onderdelen ontbreken, neem dan contact op met de verkoper van wie u het product hebt gekocht.

Het duurt ongeveer 30-45 MINUTEN om dit product in elkaar te zetten.

2 PERSONEN kunnen dit bed in elkaar zetten
DIT PAKKET BEVAT KLEINE ONDERDELEN, houd deze BUITEN BEREIK VAN KLEINE KINDEREN.

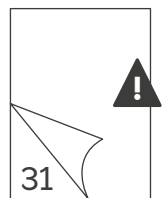
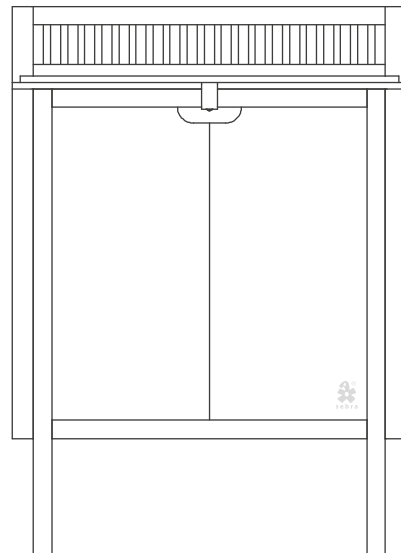
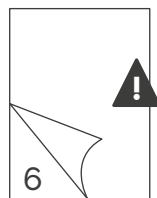
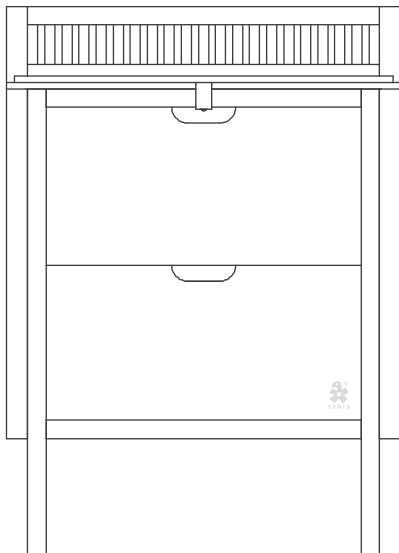
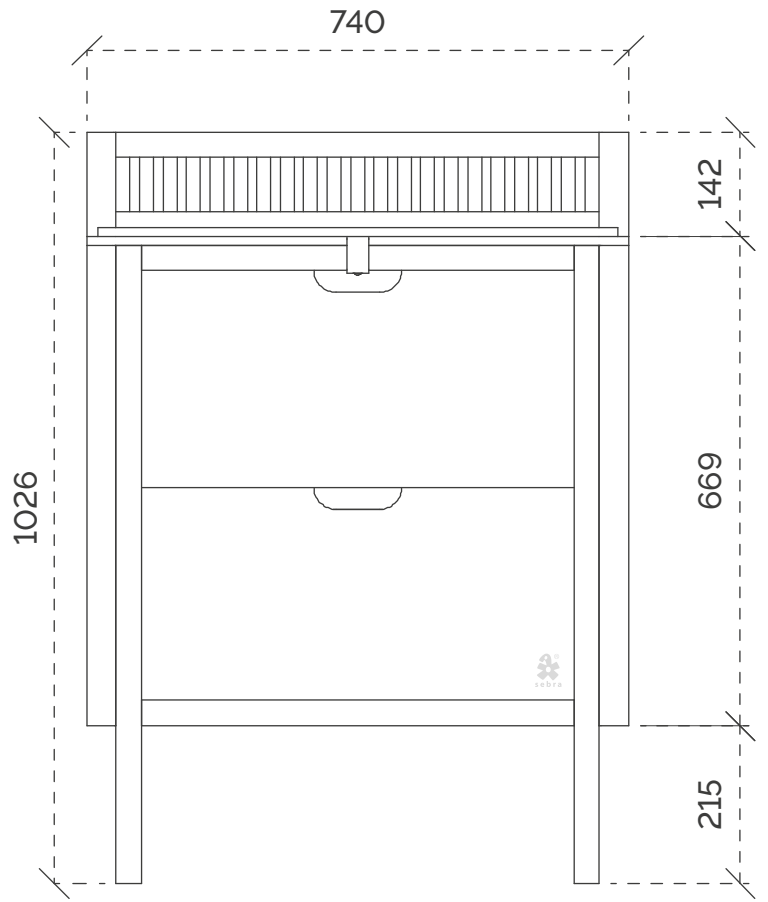
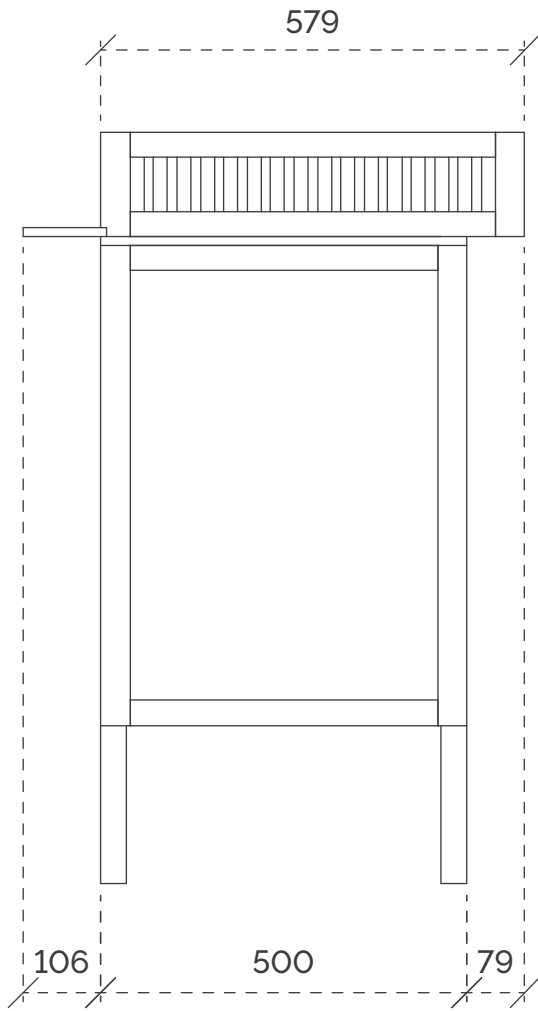

Style no.:	Classic white	Classic grey
0:	201330016	201330022
1:	201430047	201430048
2:	201430088	201430072
3:	201430074	201430073
4:	201430076	201430075
5:	201430078	201430077
5A:	201430096	201430095
6:	201430097	201430097
7:	201430080	201430079
8:	201430082	201430081
9A:	201430084	201430083
9B:	201430086	201430085
10:	201430050	201430049
11:	201430052	201430051
12:	201430054	201430053
13:	201430056	201430055
14:	201430057	201430057
15:	201430058	201430058

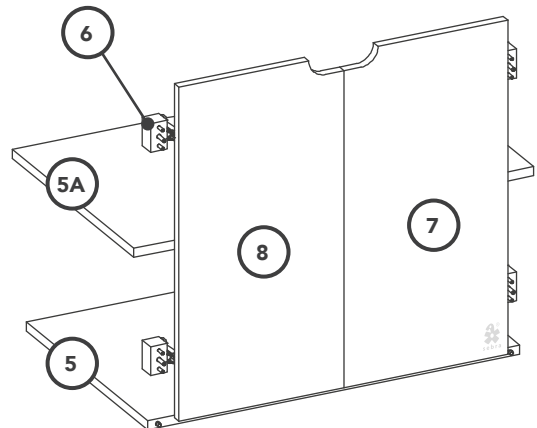
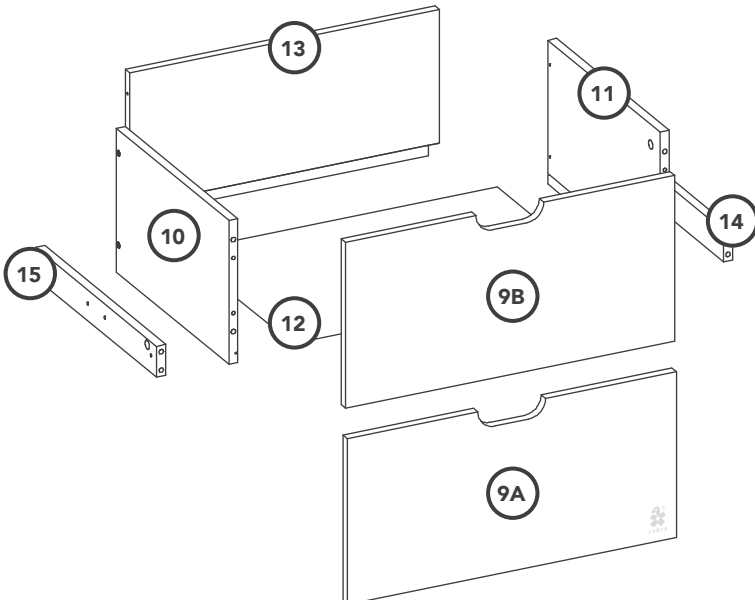
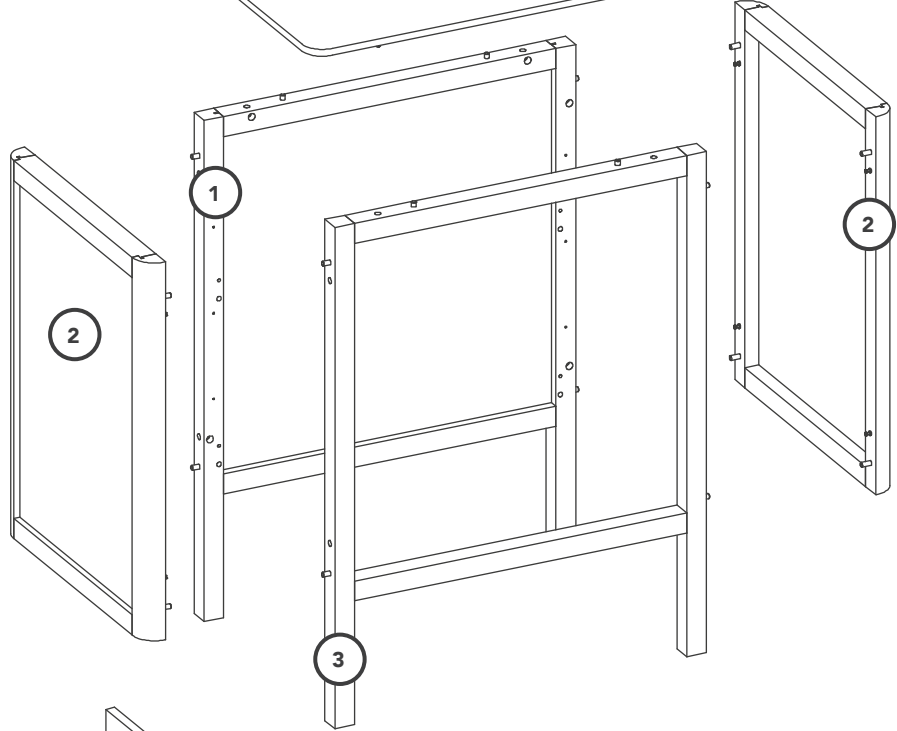
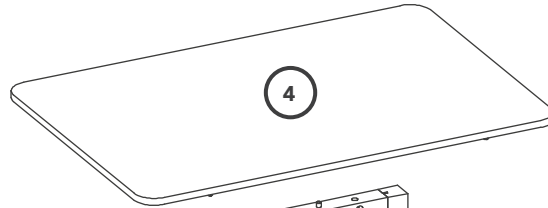
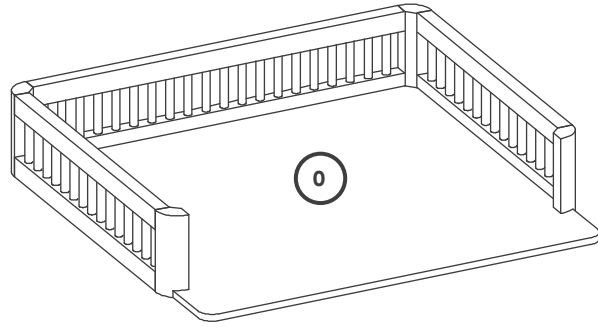

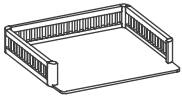

B 1 x 201430059

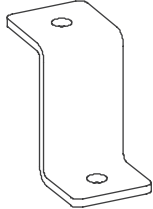

C 2 x 201430060

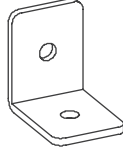

A 6 x 201430087
M4 x 12 mm

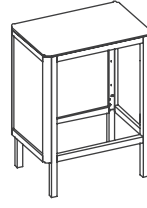

D 12 x 201030098
Ø8 x 30 mm



E 12 x 201030099
Ø5 x 7,8 mm

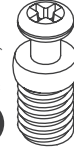

L 12 x 201030106
Ø12 x 12

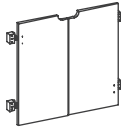
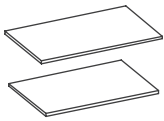

P 4 x 201030102
M7 x 50 mm (SW4)

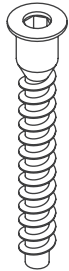

G 8 x 201030101
Ø5 x 30 mm

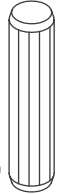

M 8 x 201030109
Ø3,5 x 16 mm

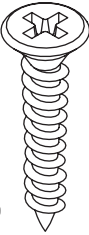

J 8 x 201030104
Ø6 x 13 mm



E 4 x 201030099
Ø5 x 7,8 mm

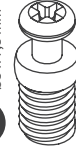

S 6 x 201030111



T 4 x 201030110

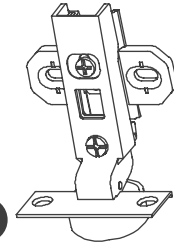

Q 1 x 201030115
SW4

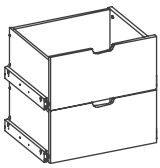

F 16 x 201030100
Ø5 x 34 mm

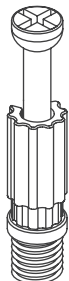

D 8 x 201030098
Ø8 x 30 mm

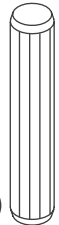

I 16 x 201030103
Ø15 x 12



G 8 x 201030101
Ø5 x 30 mm



M 8 x 201030109
Ø3,5 x 16 mm

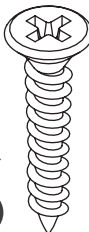

J 8 x 201030104
Ø6 x 13 mm



H 8 x 201030114
M5 x 40 mm (SW3)



N 1 x 201030116
SW3

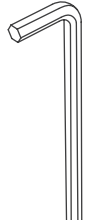

K 4 x 201030105
QUADRO 400

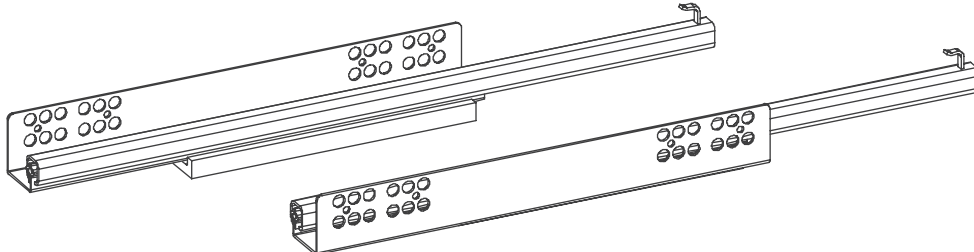

V 4 x 201030170

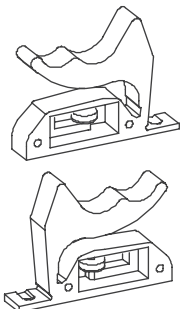

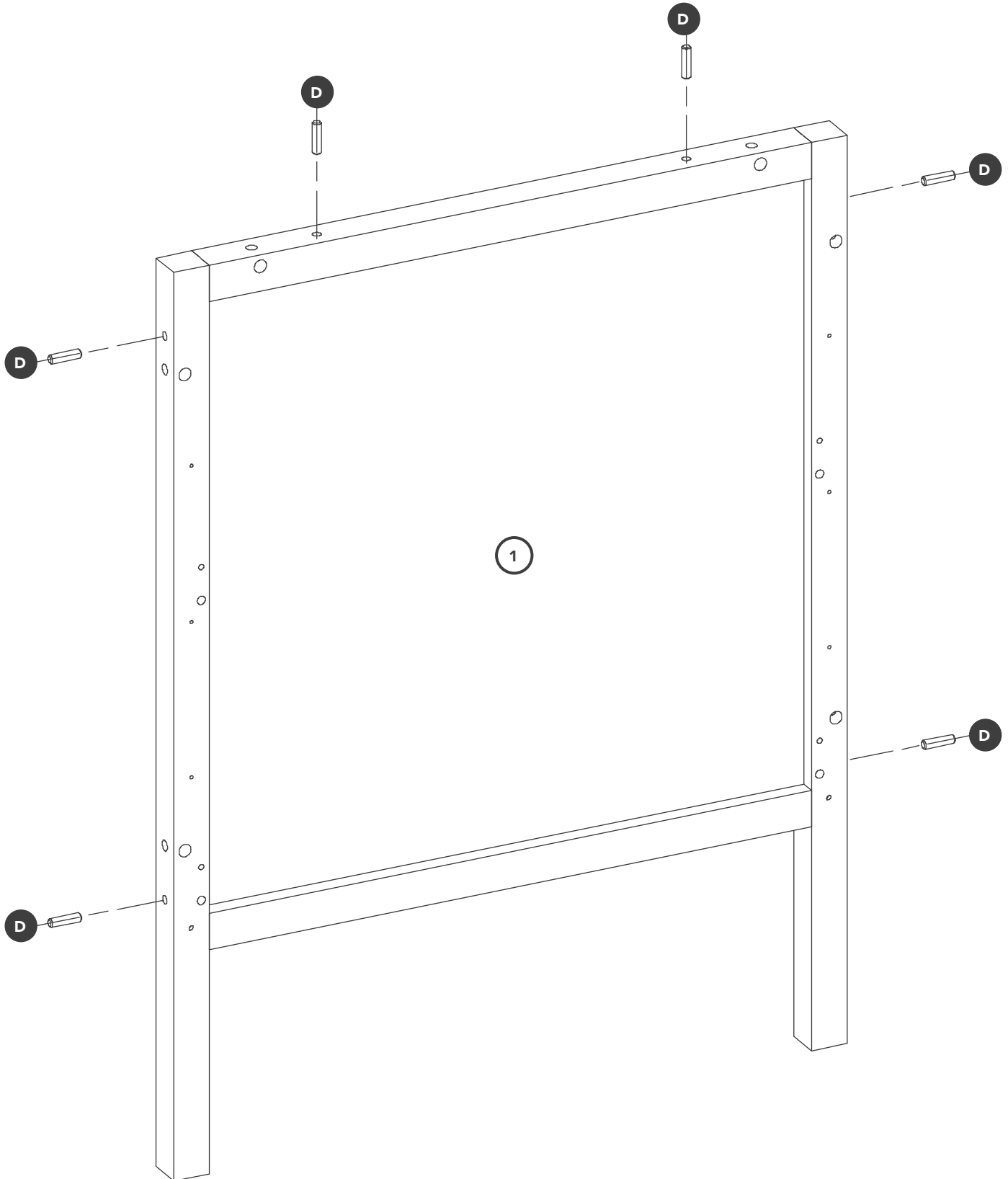

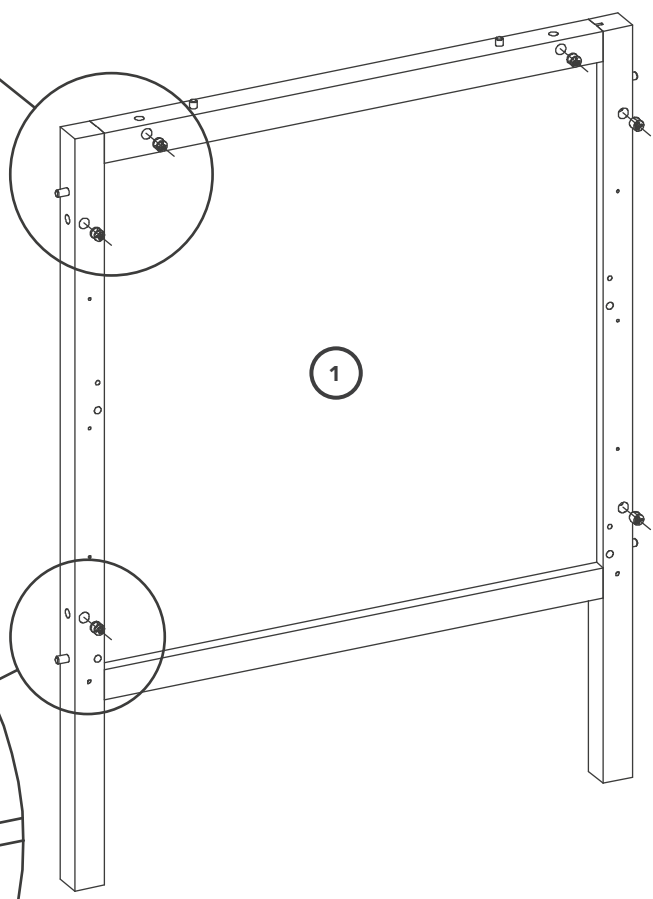
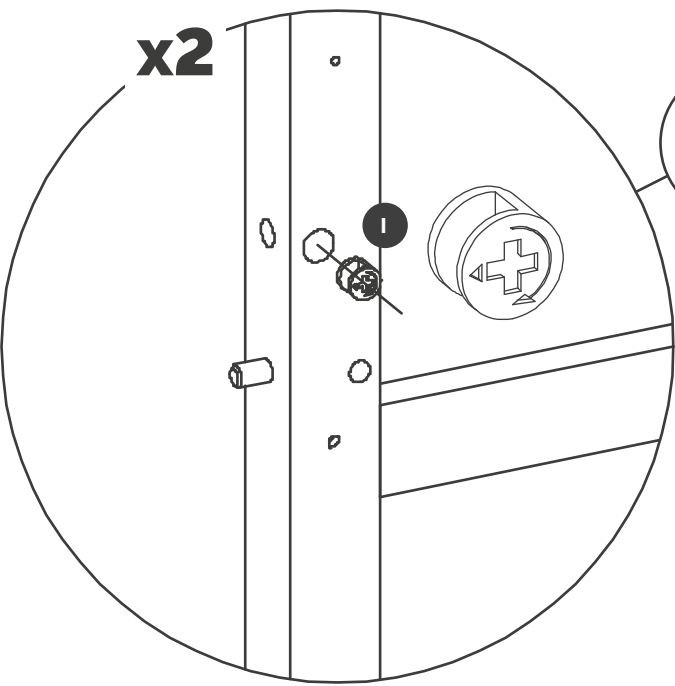
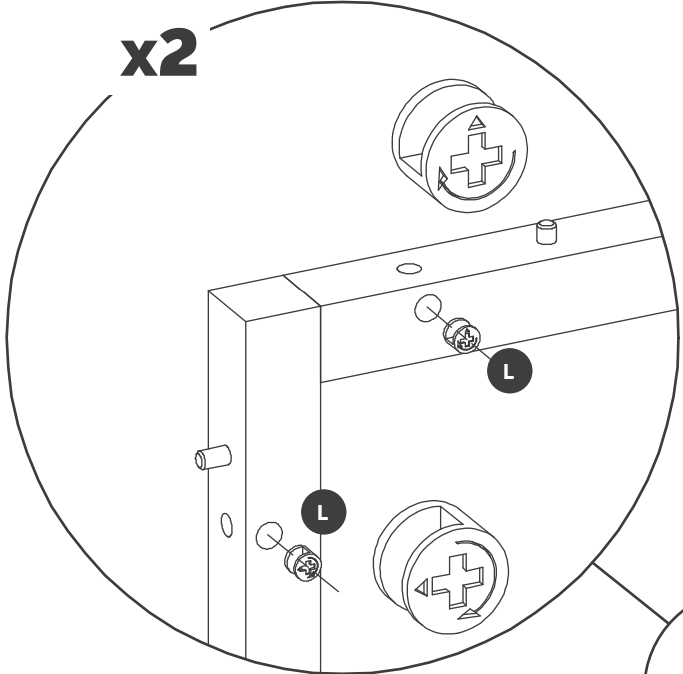

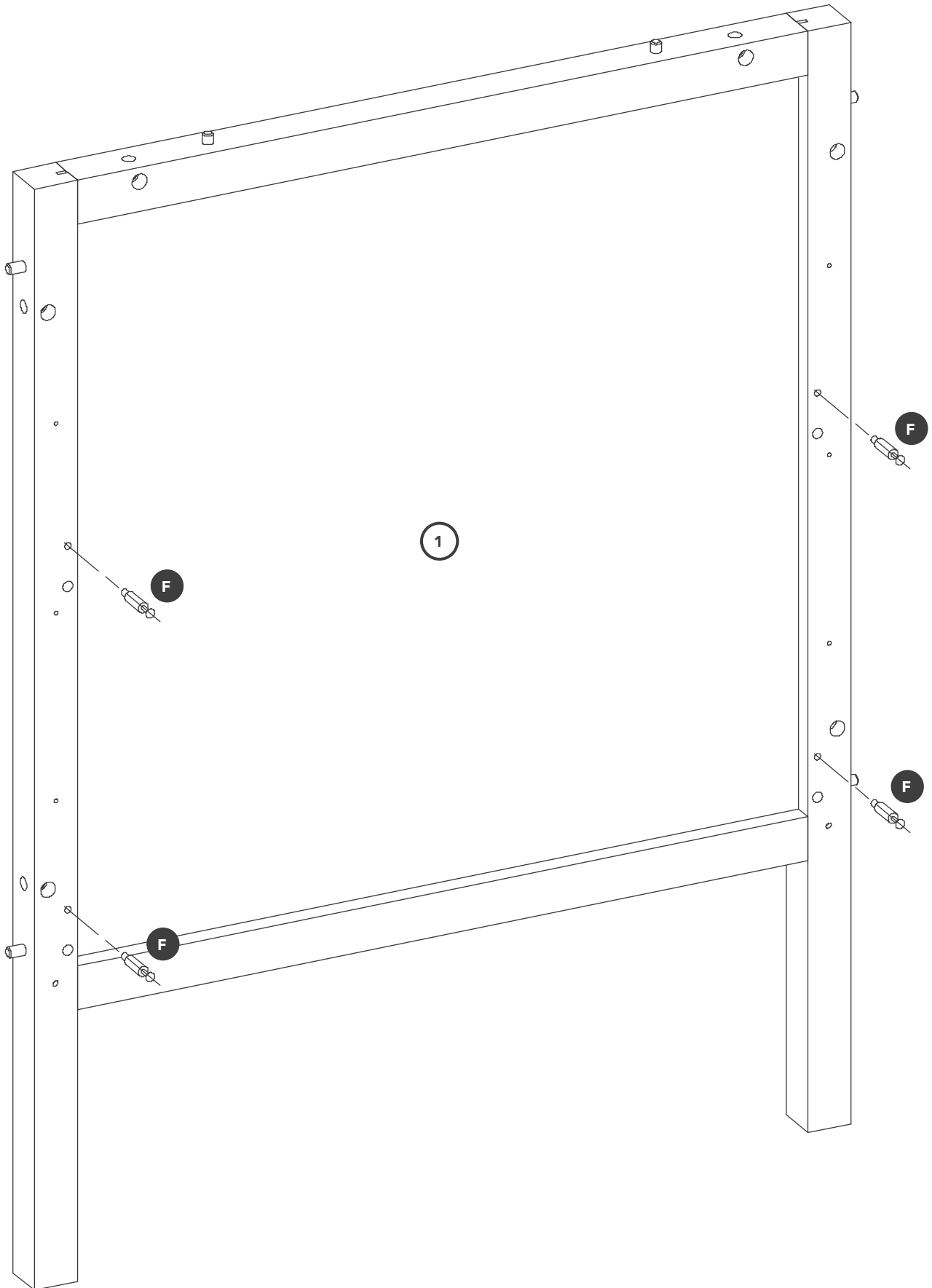

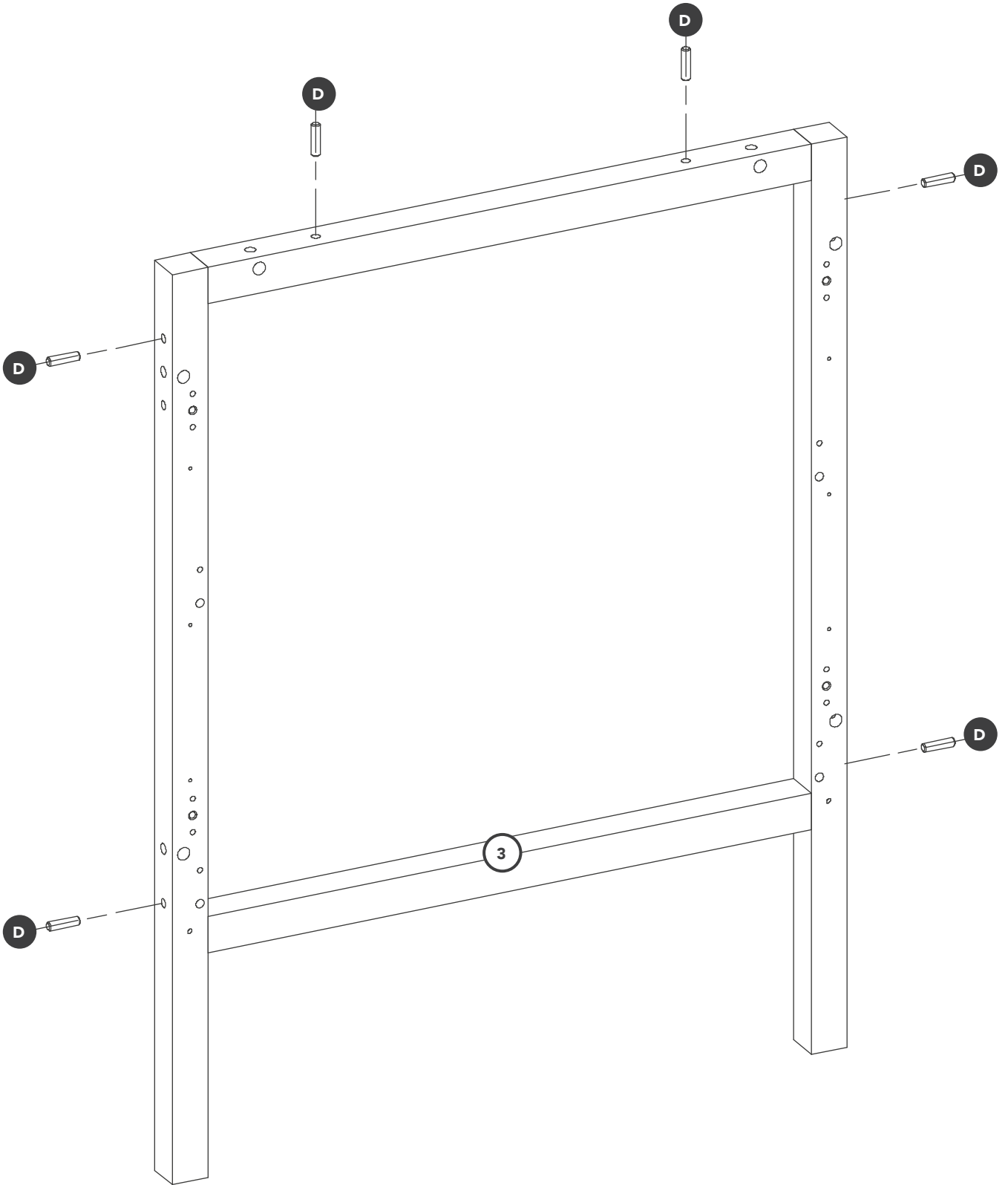

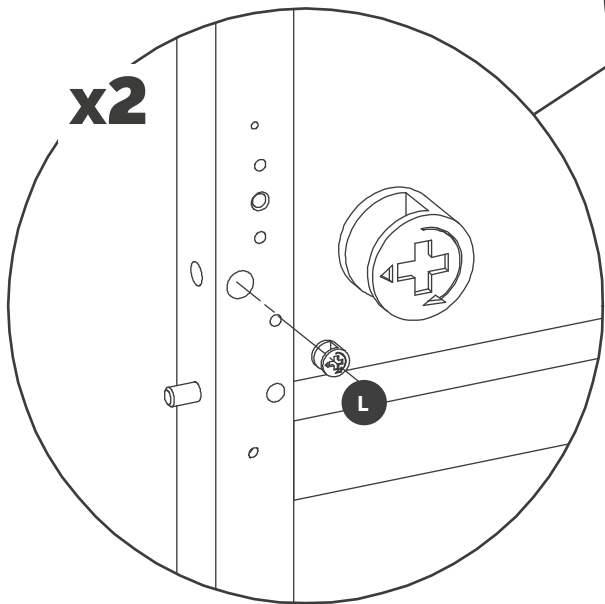
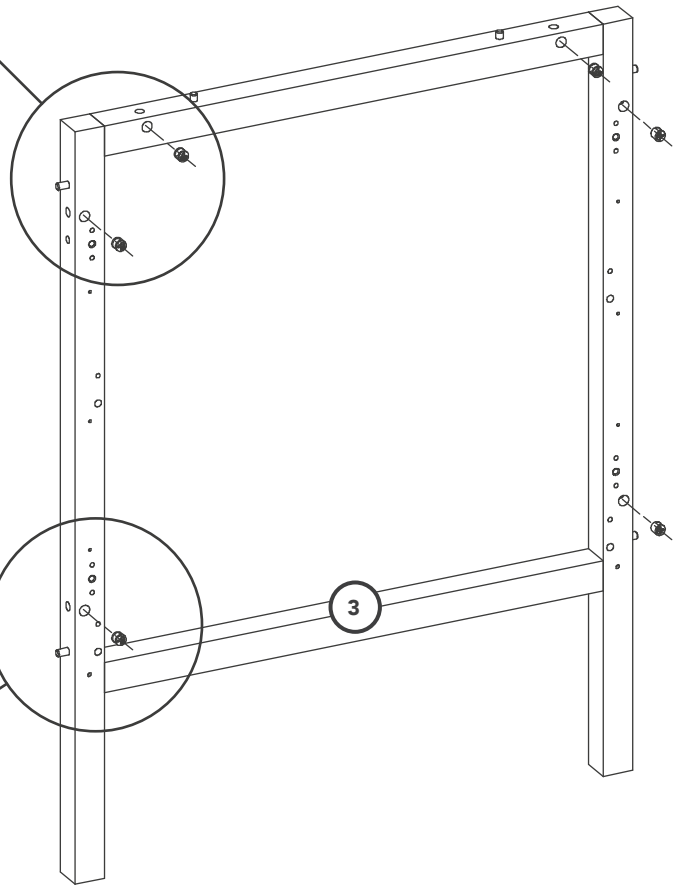
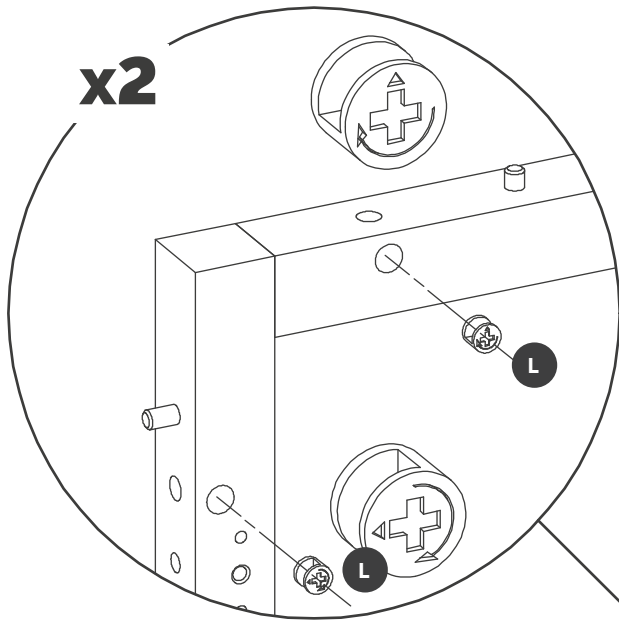

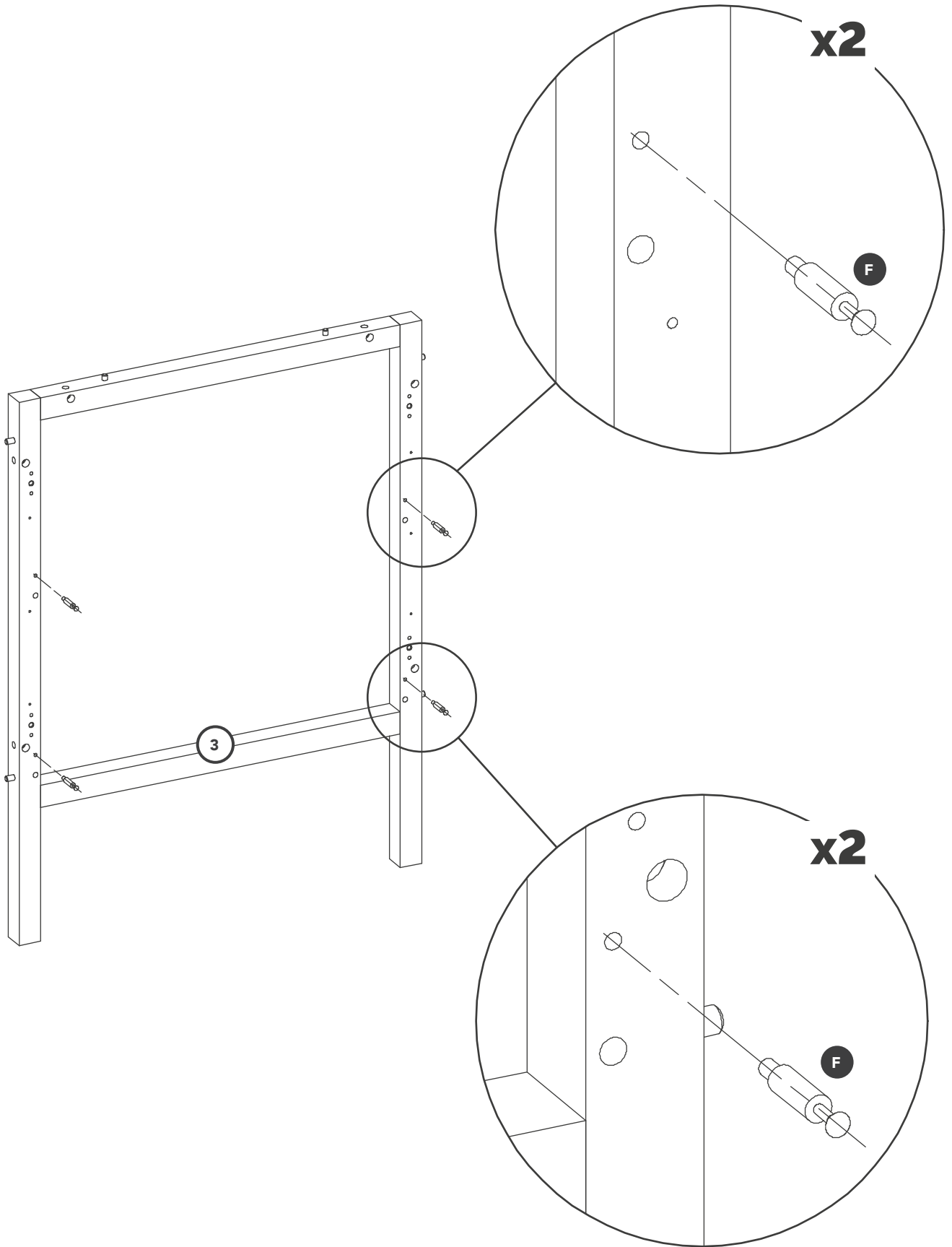

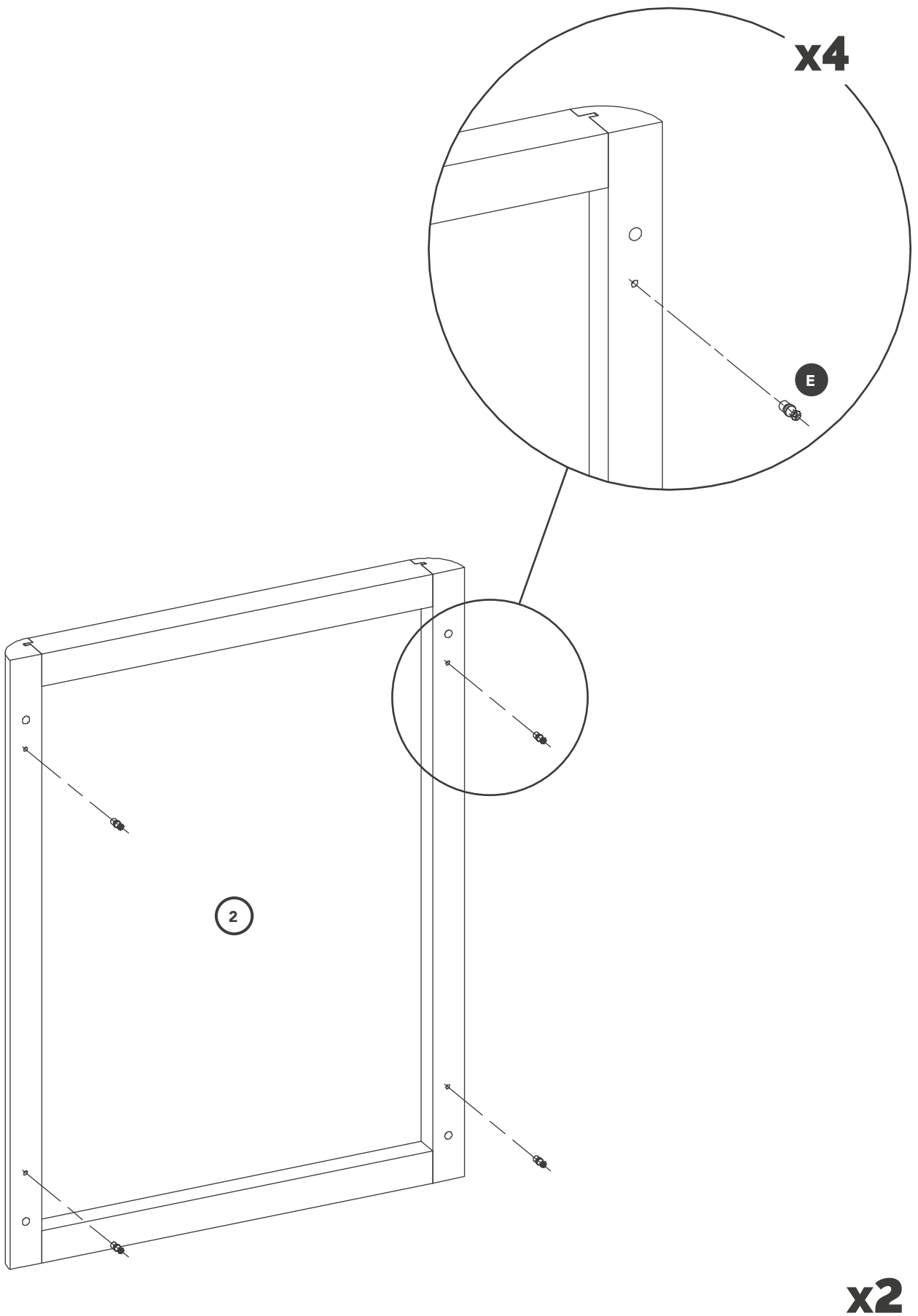

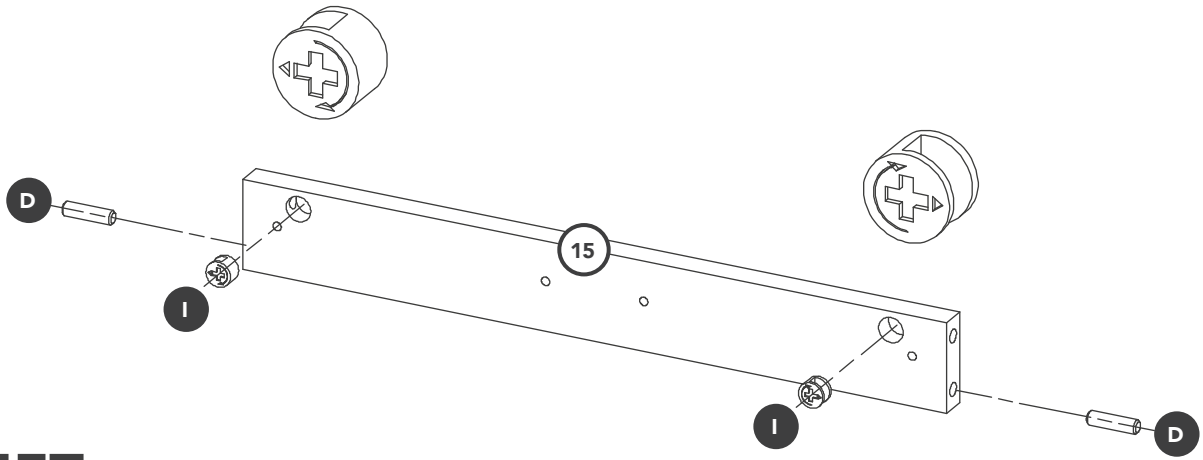

LEFT

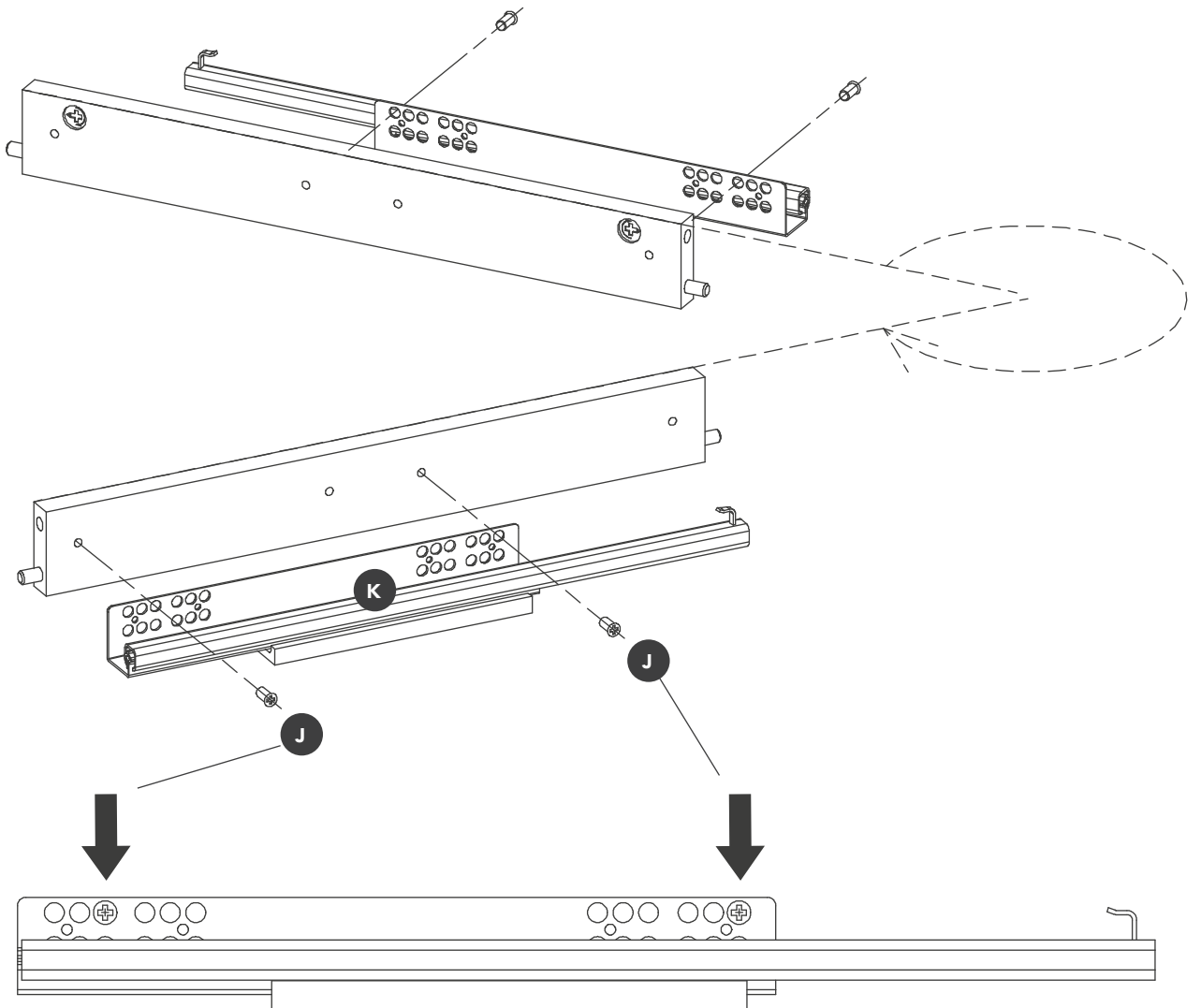

x2

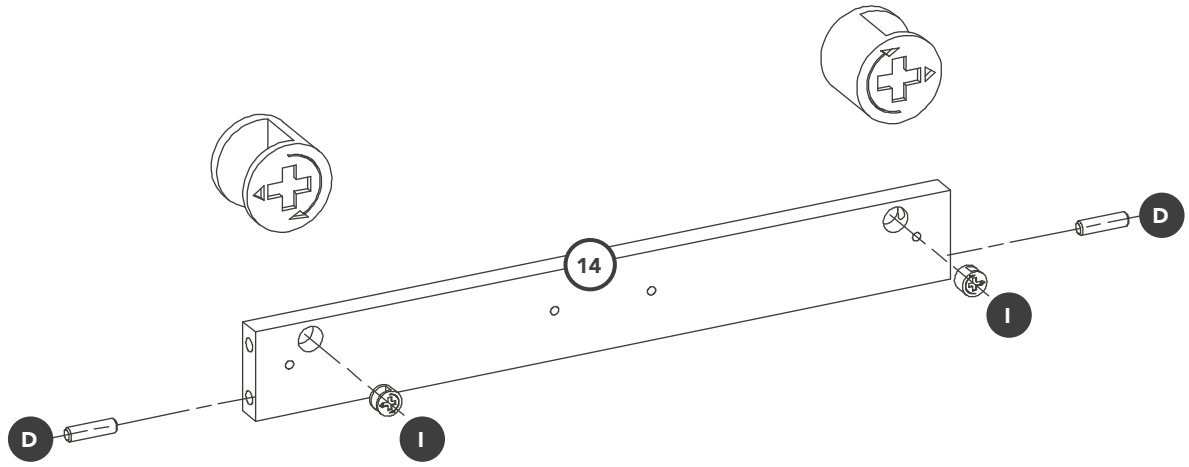

RIGHT

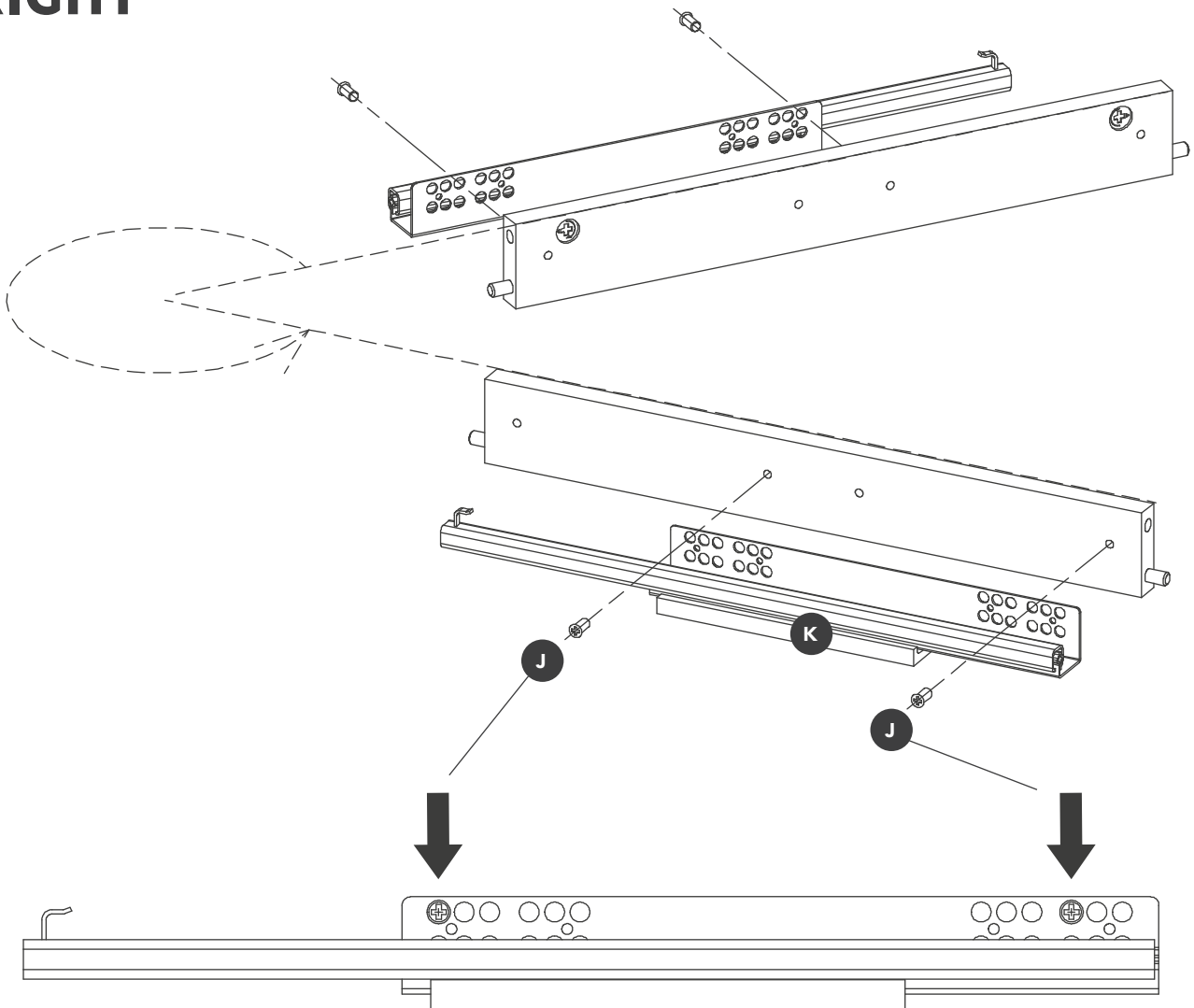

x2

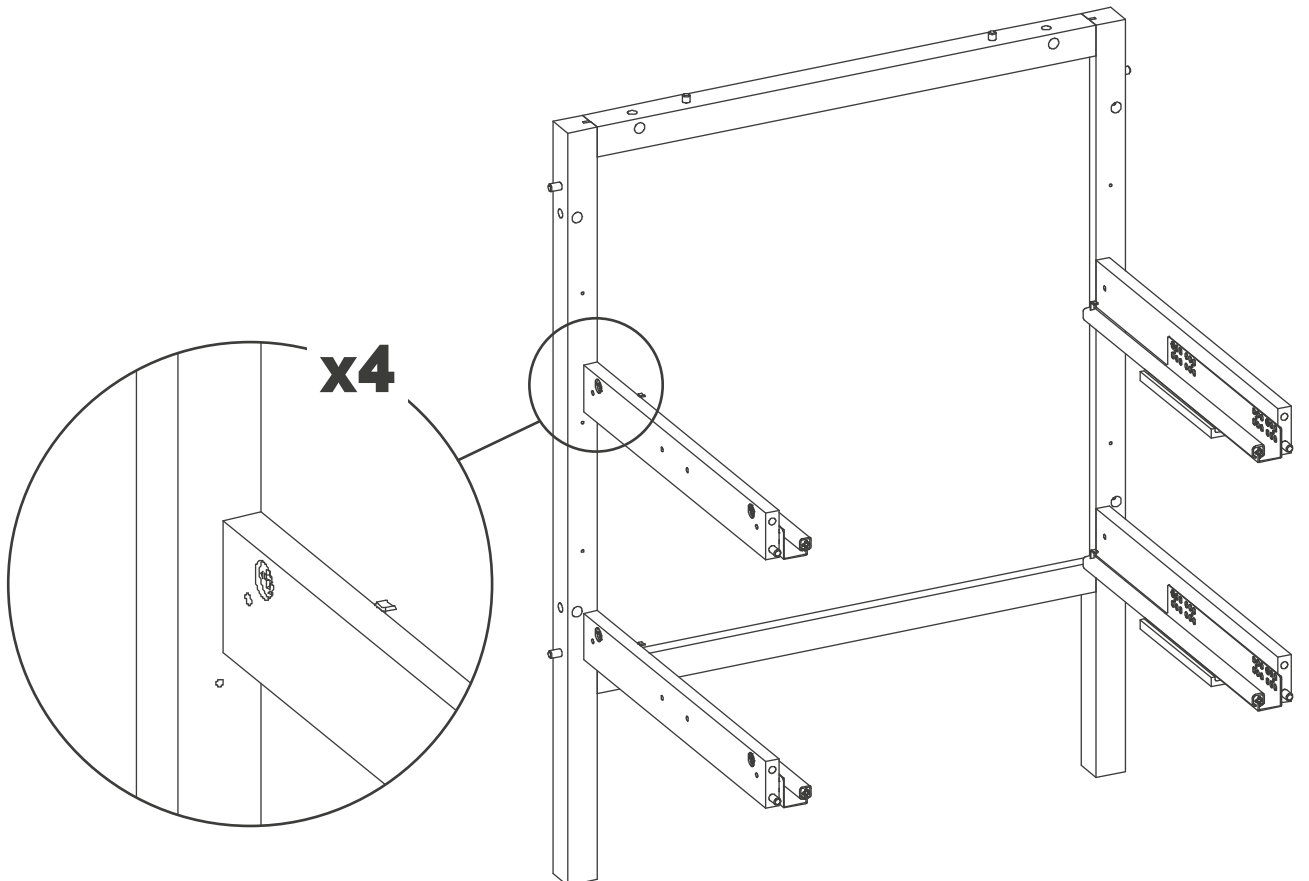
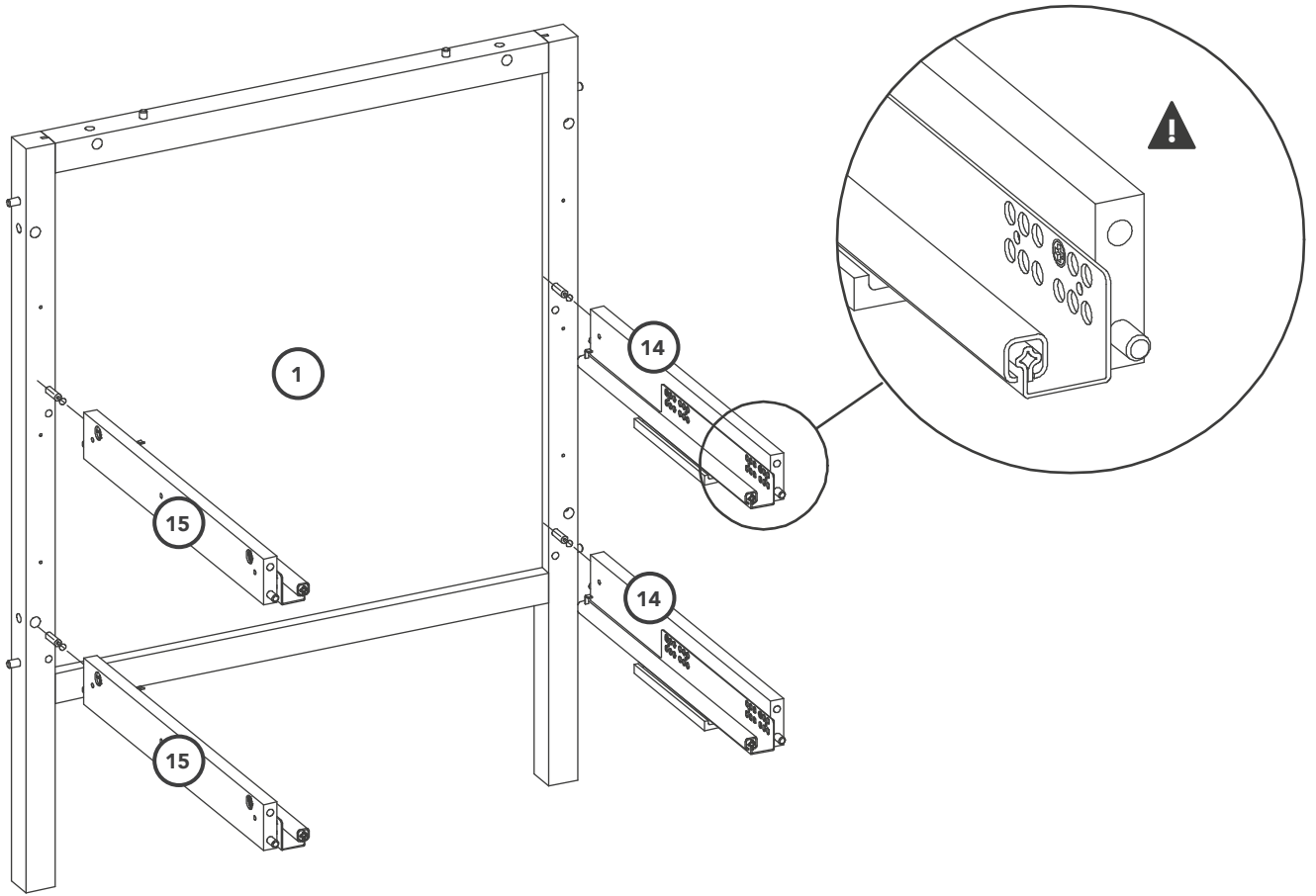

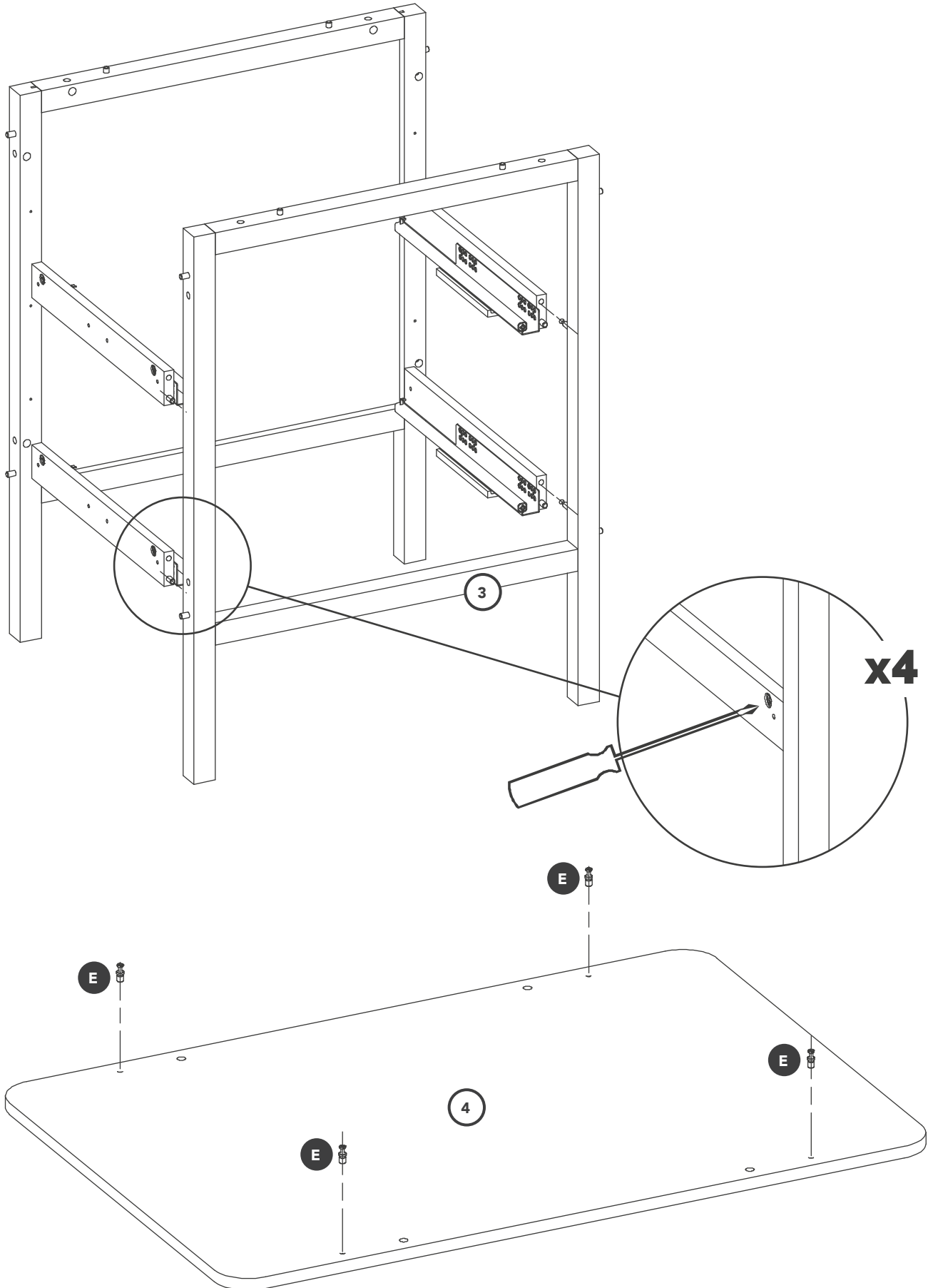

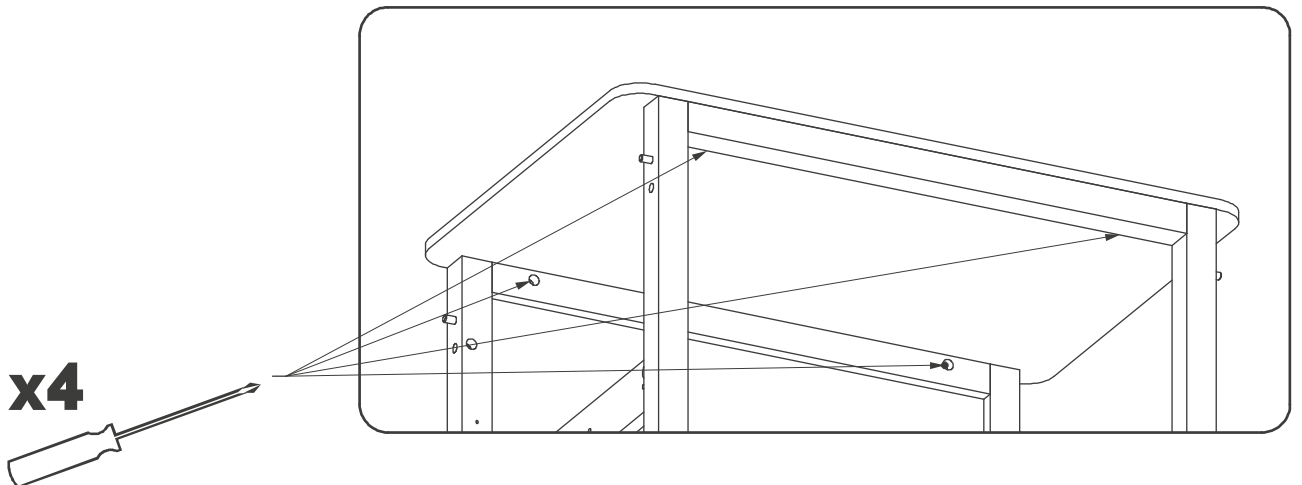
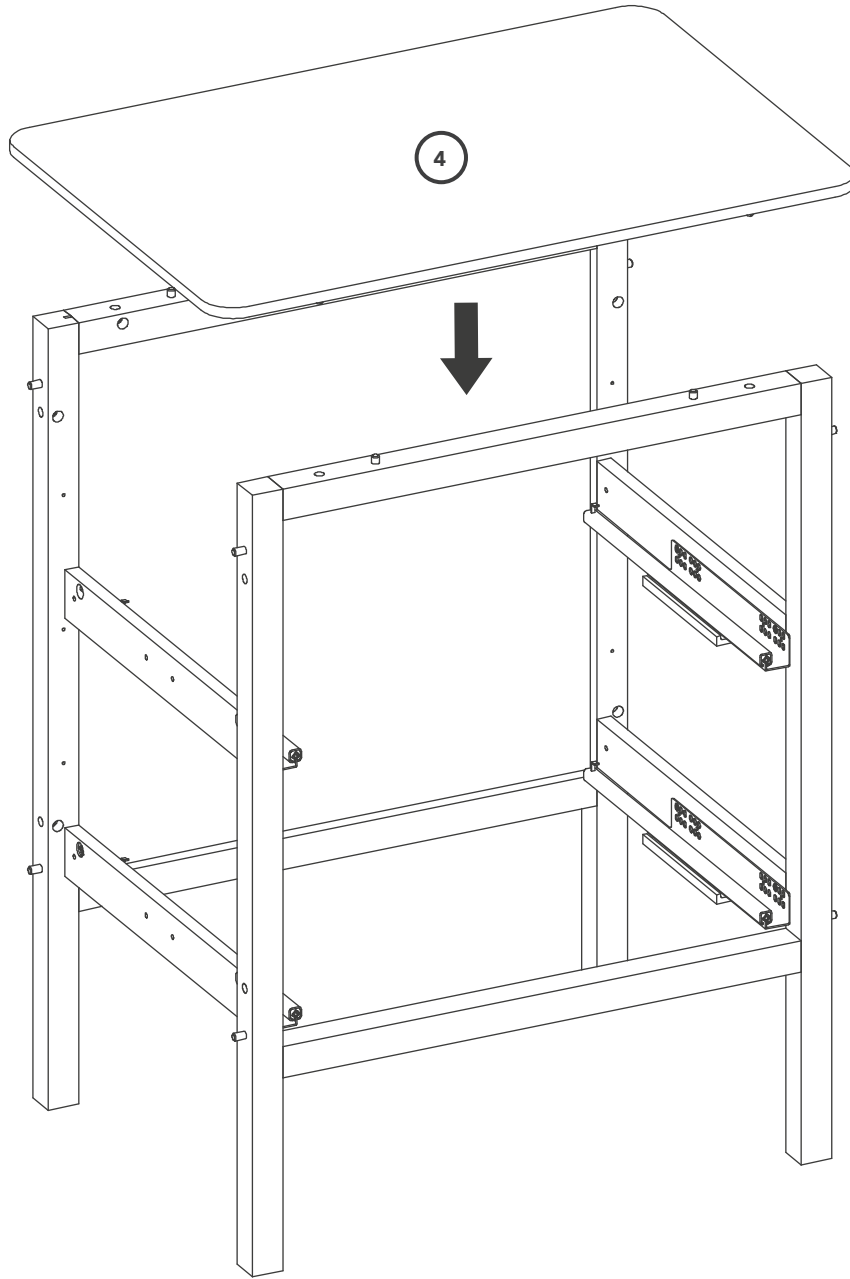

x4

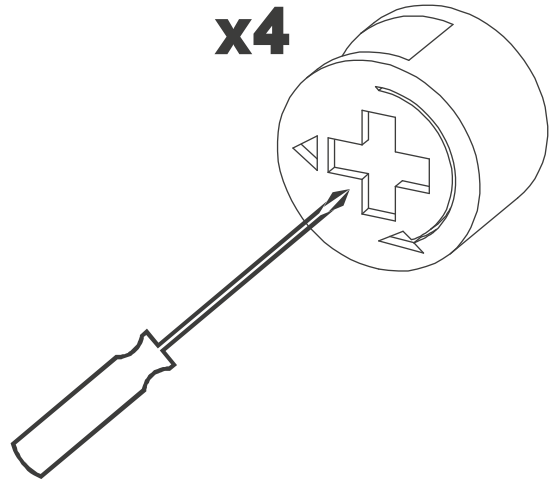

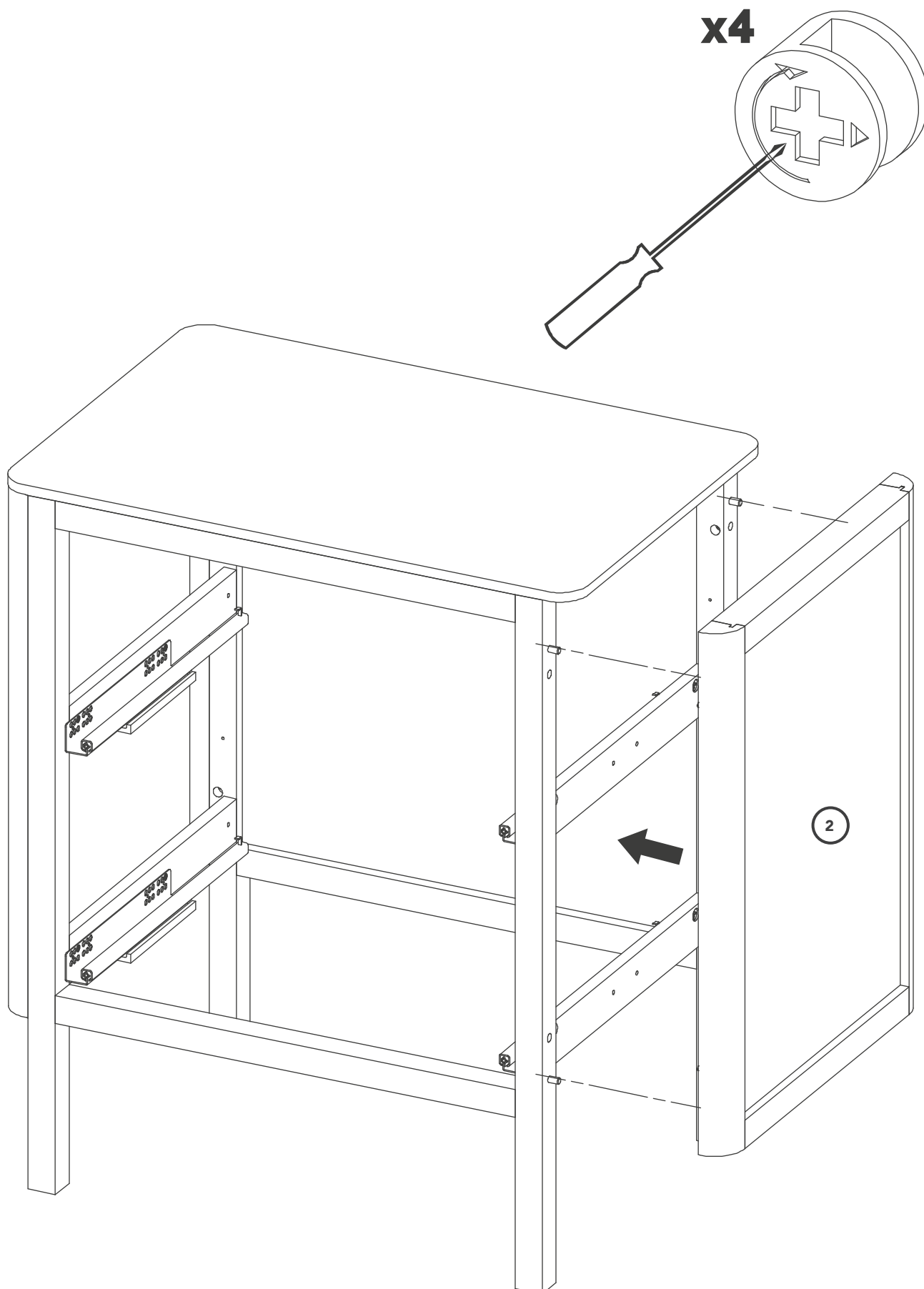

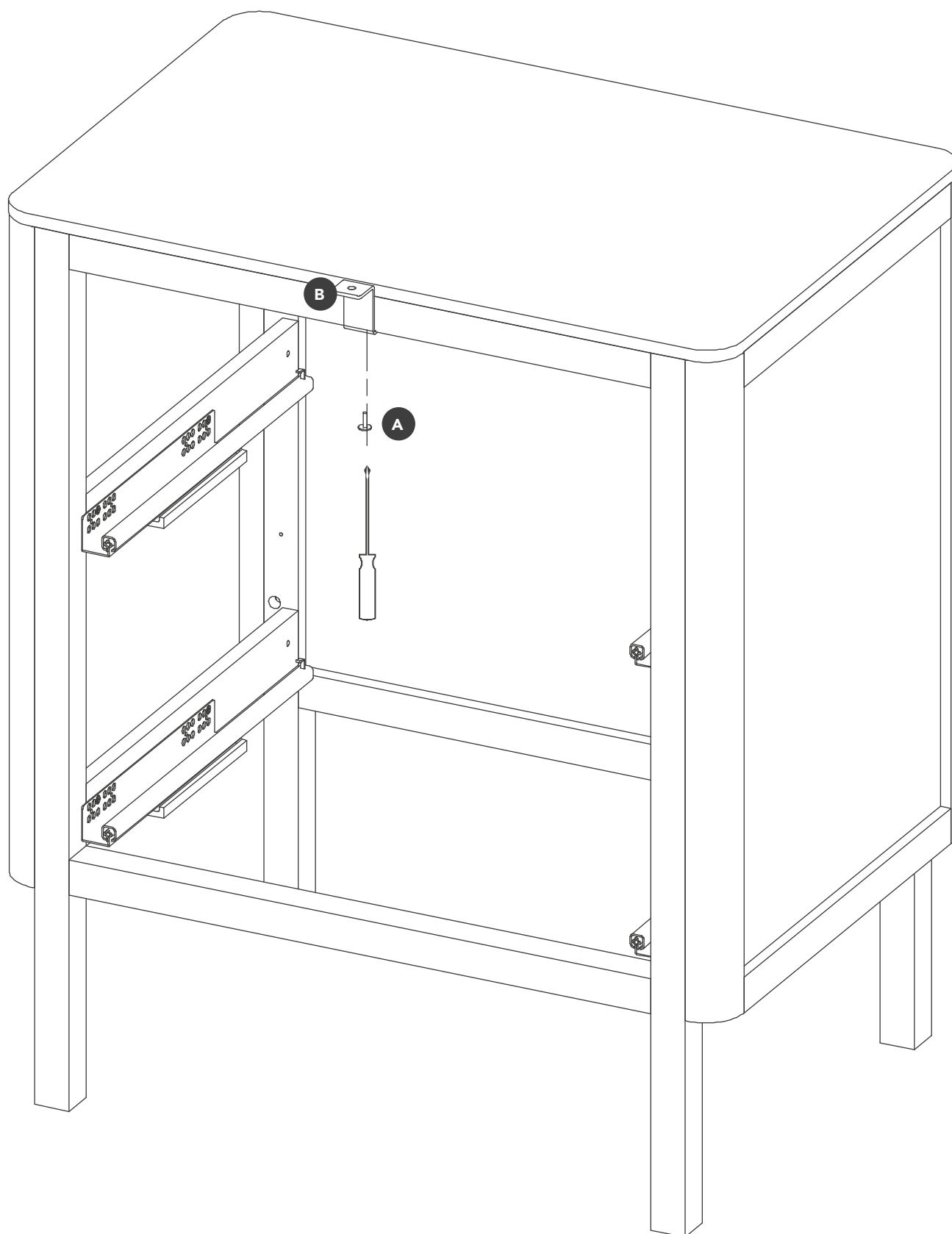

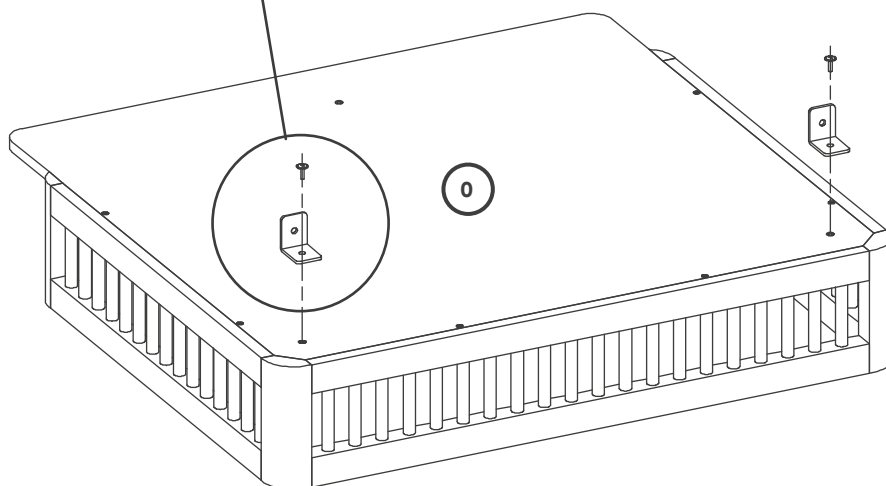
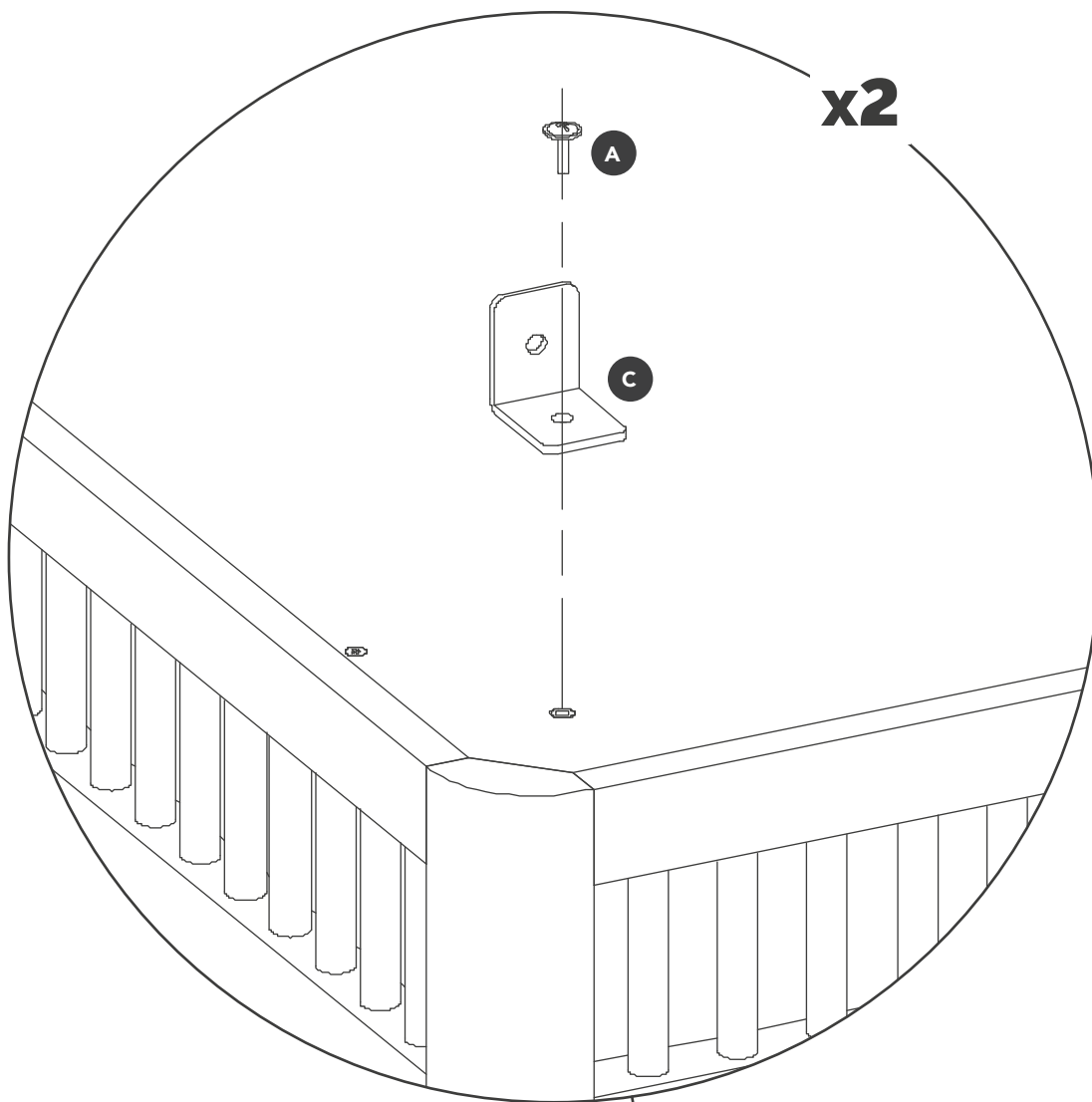

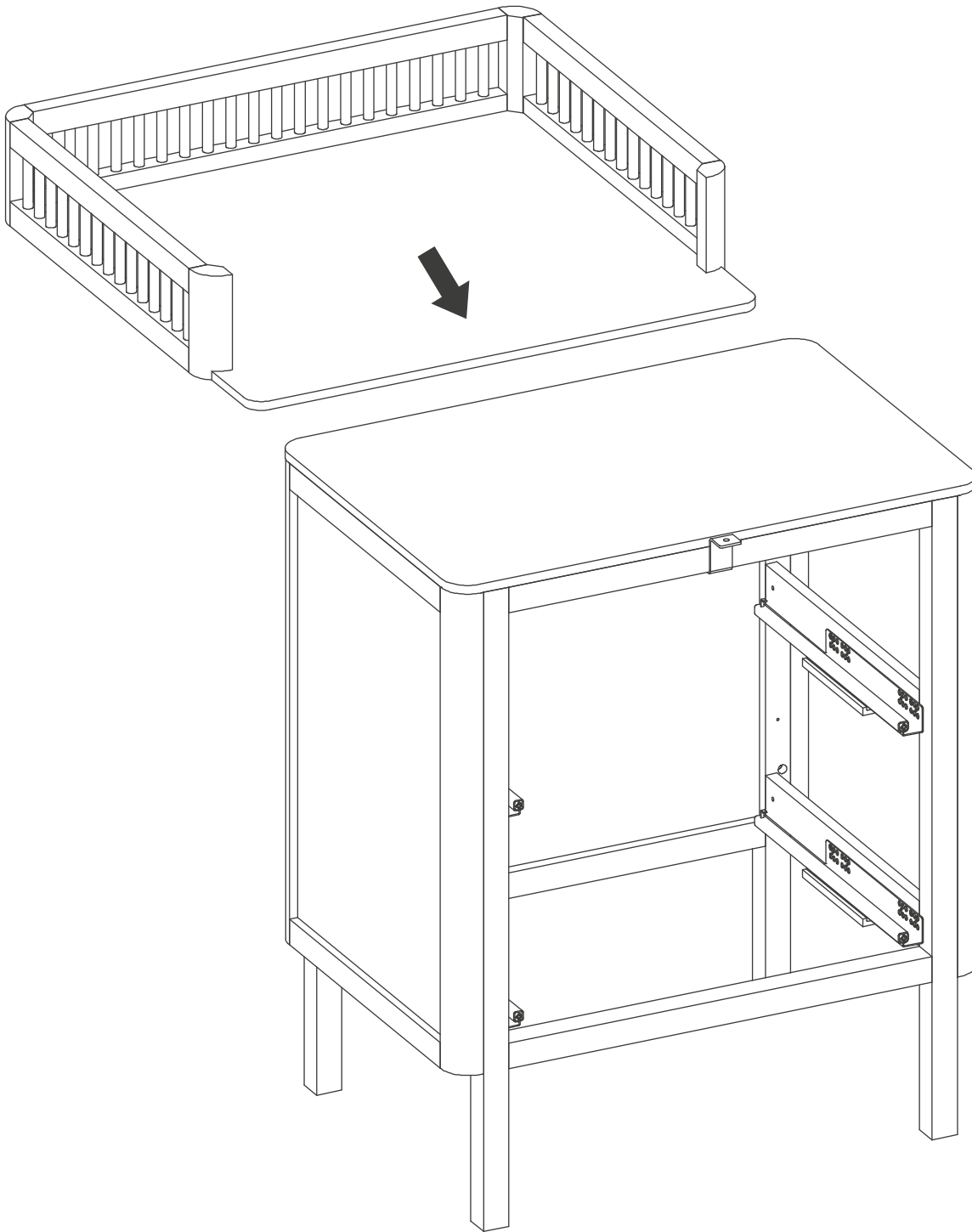

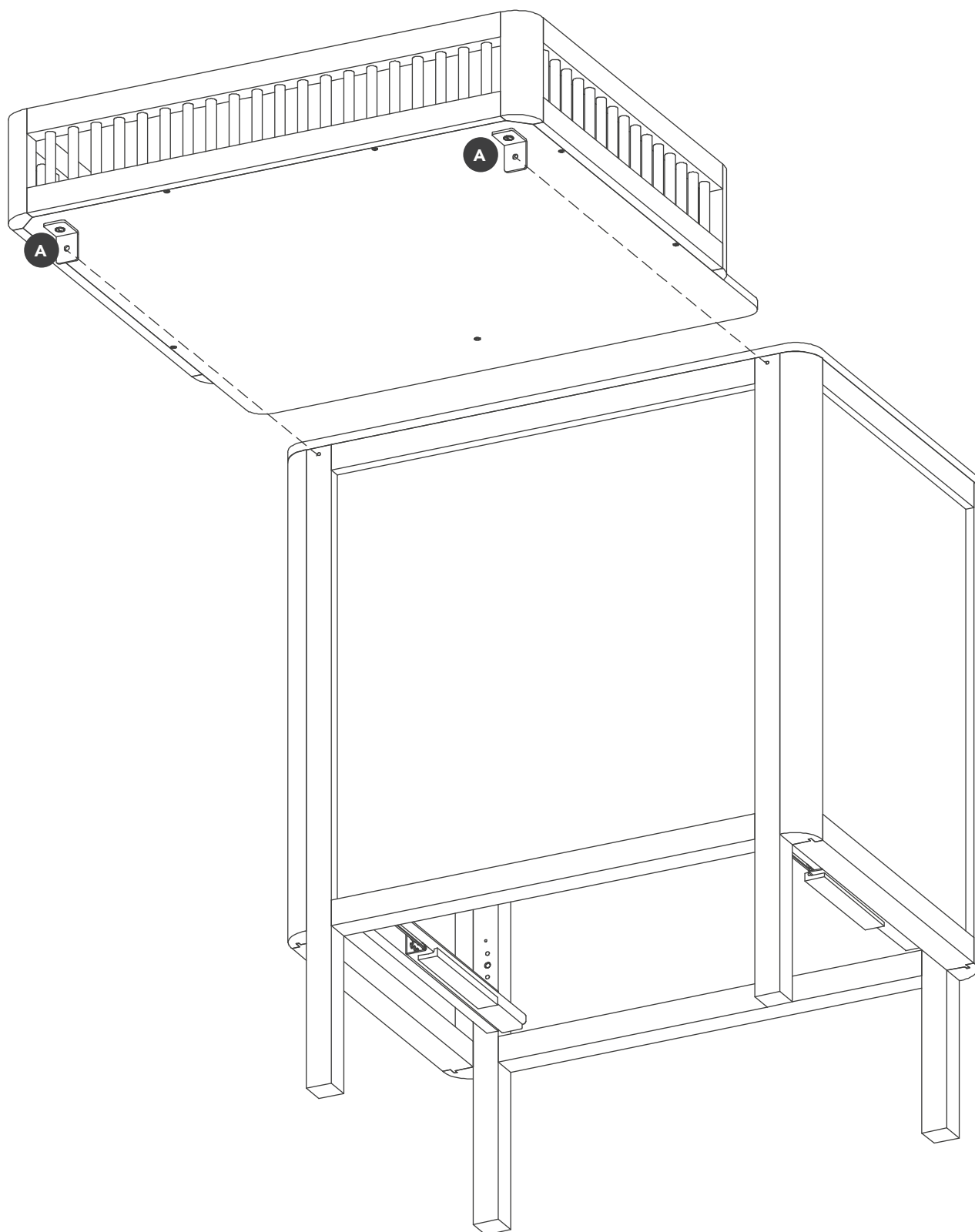

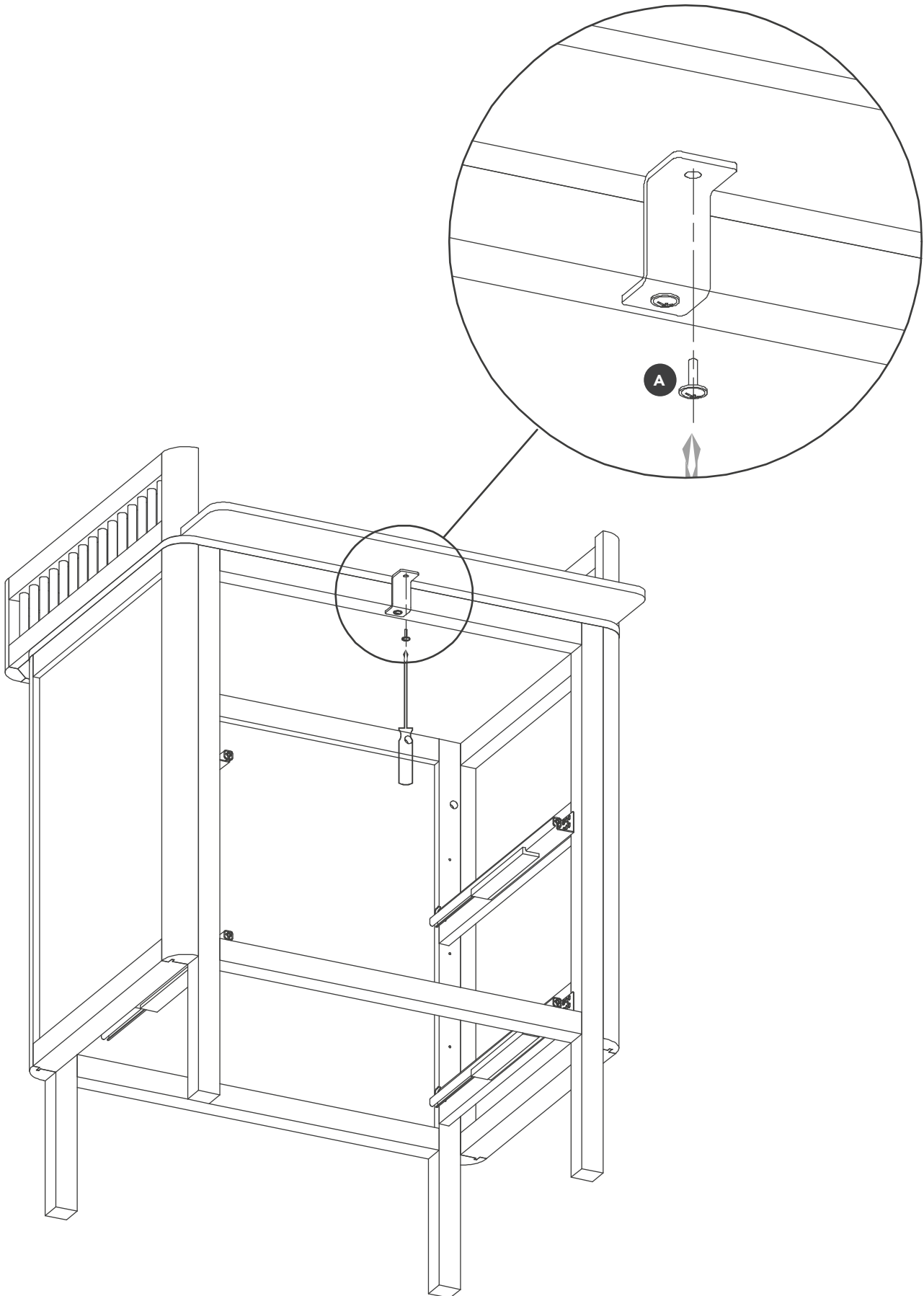

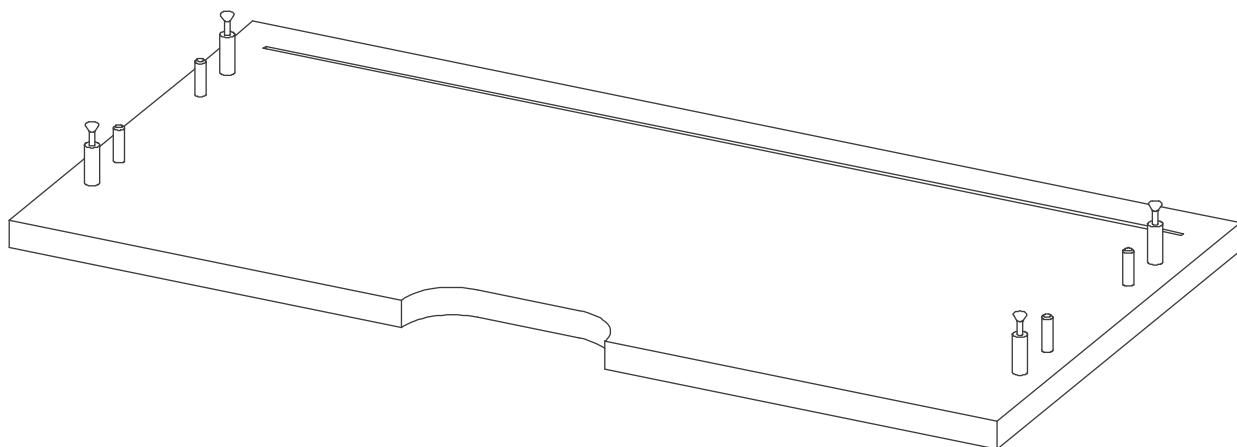
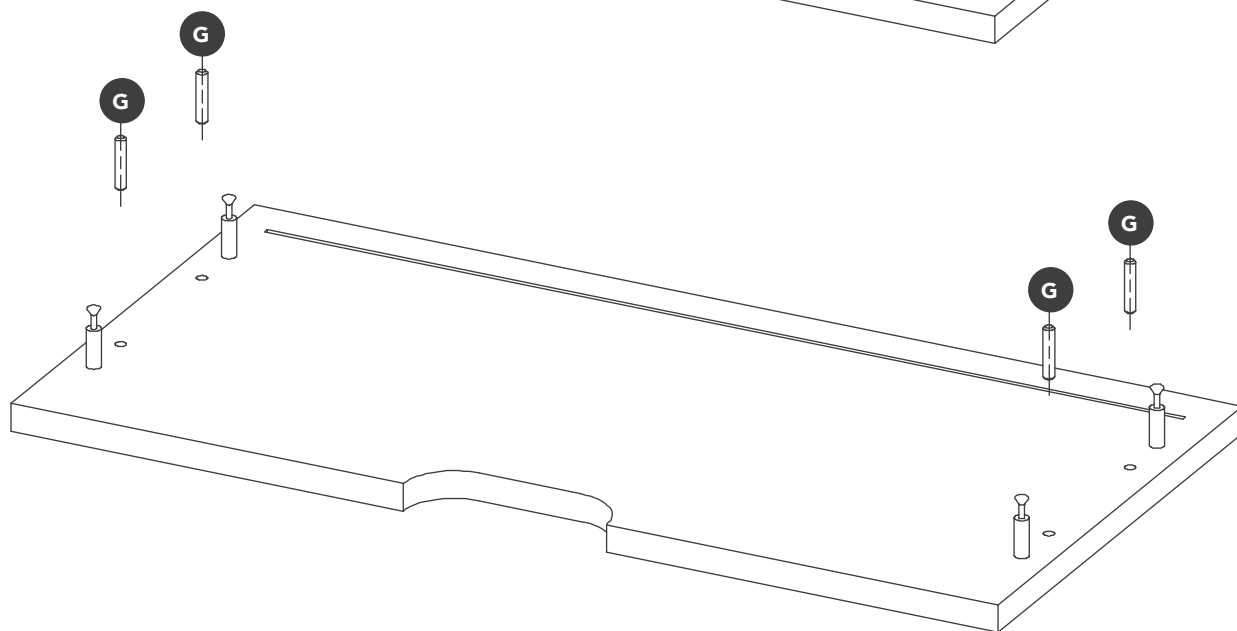
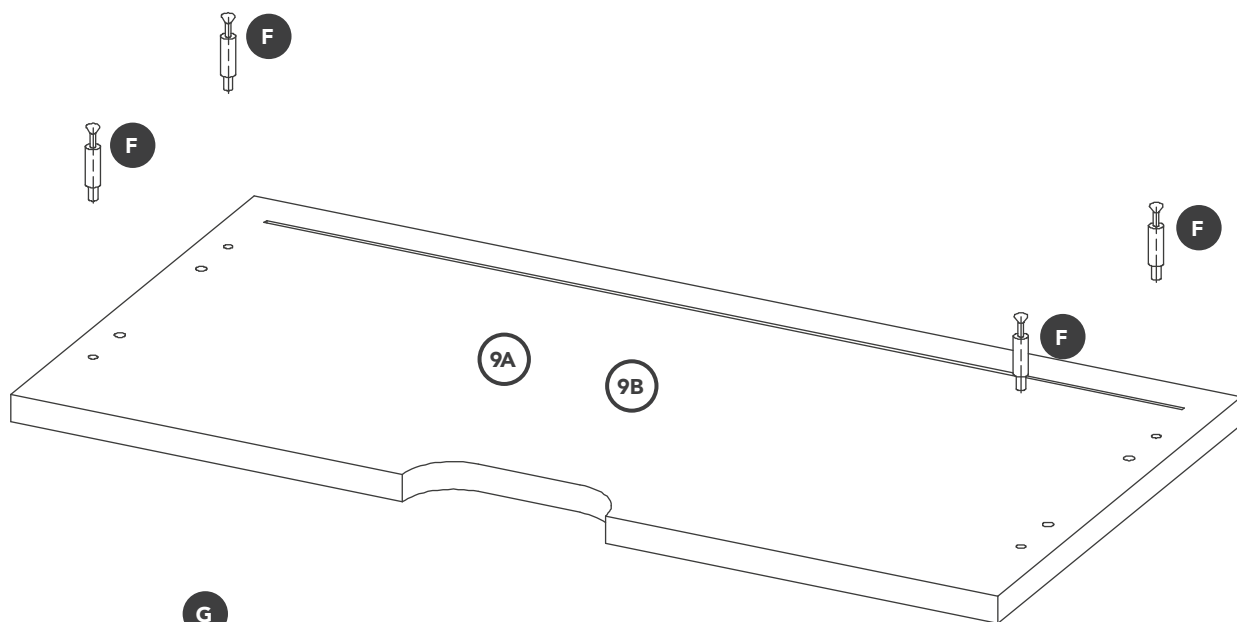

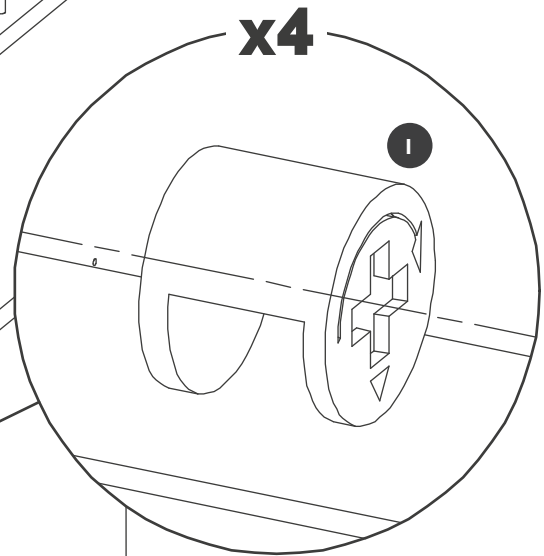
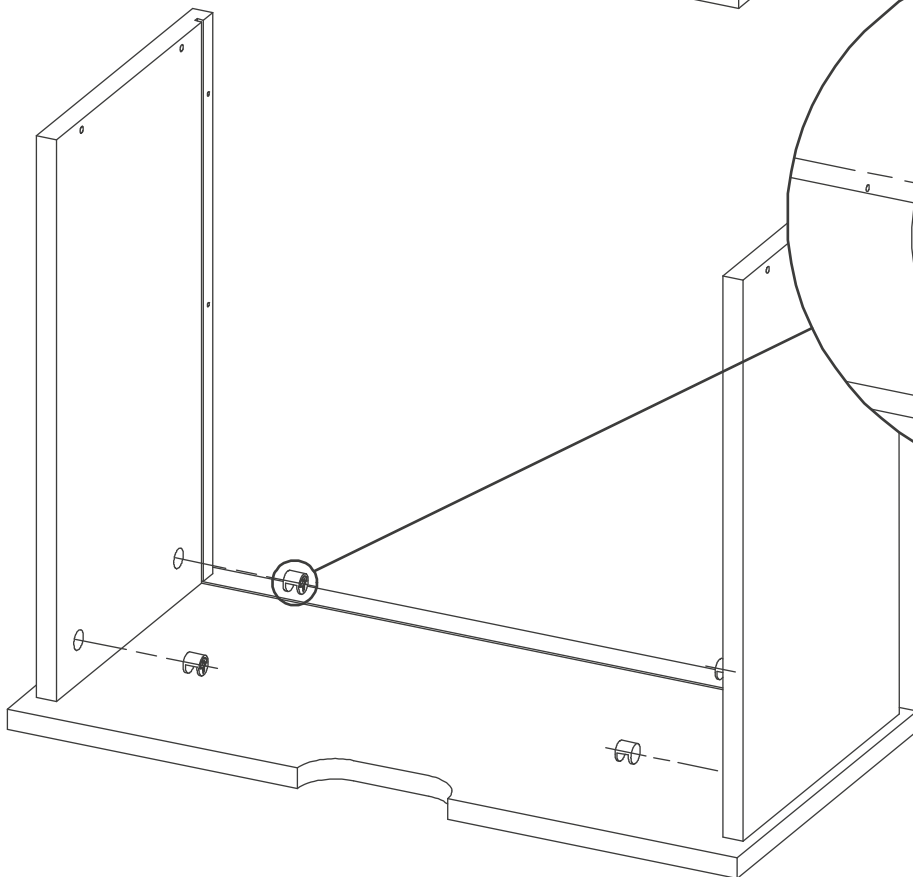
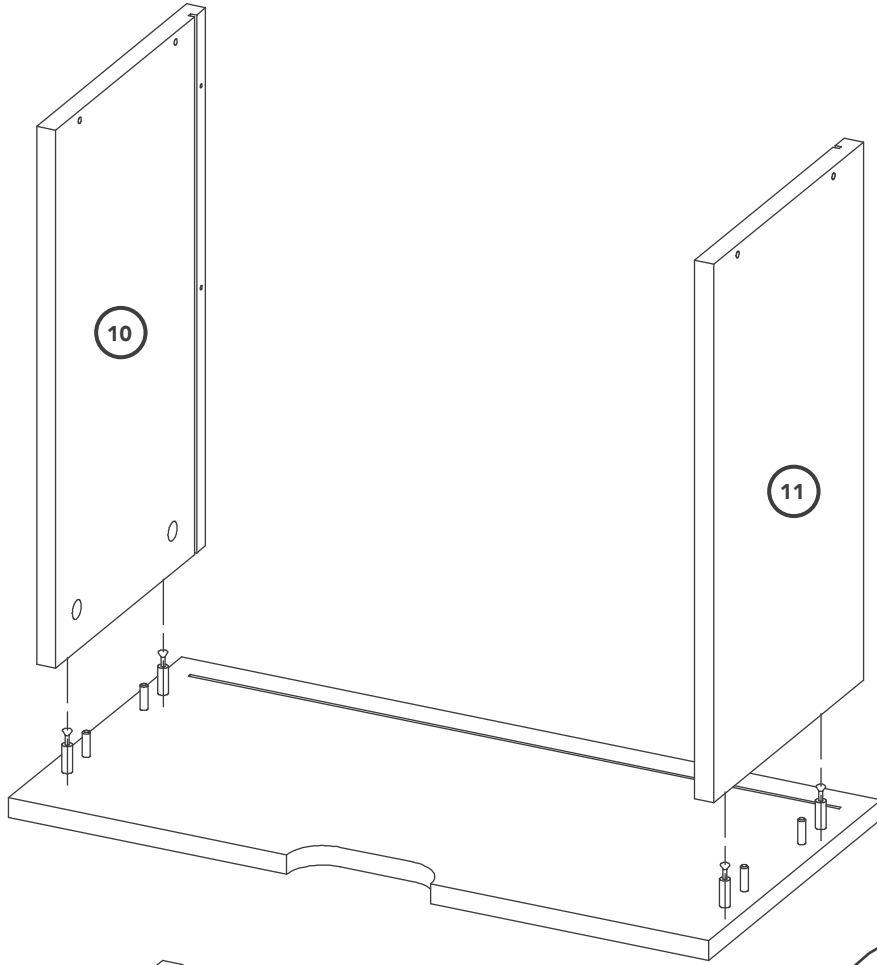

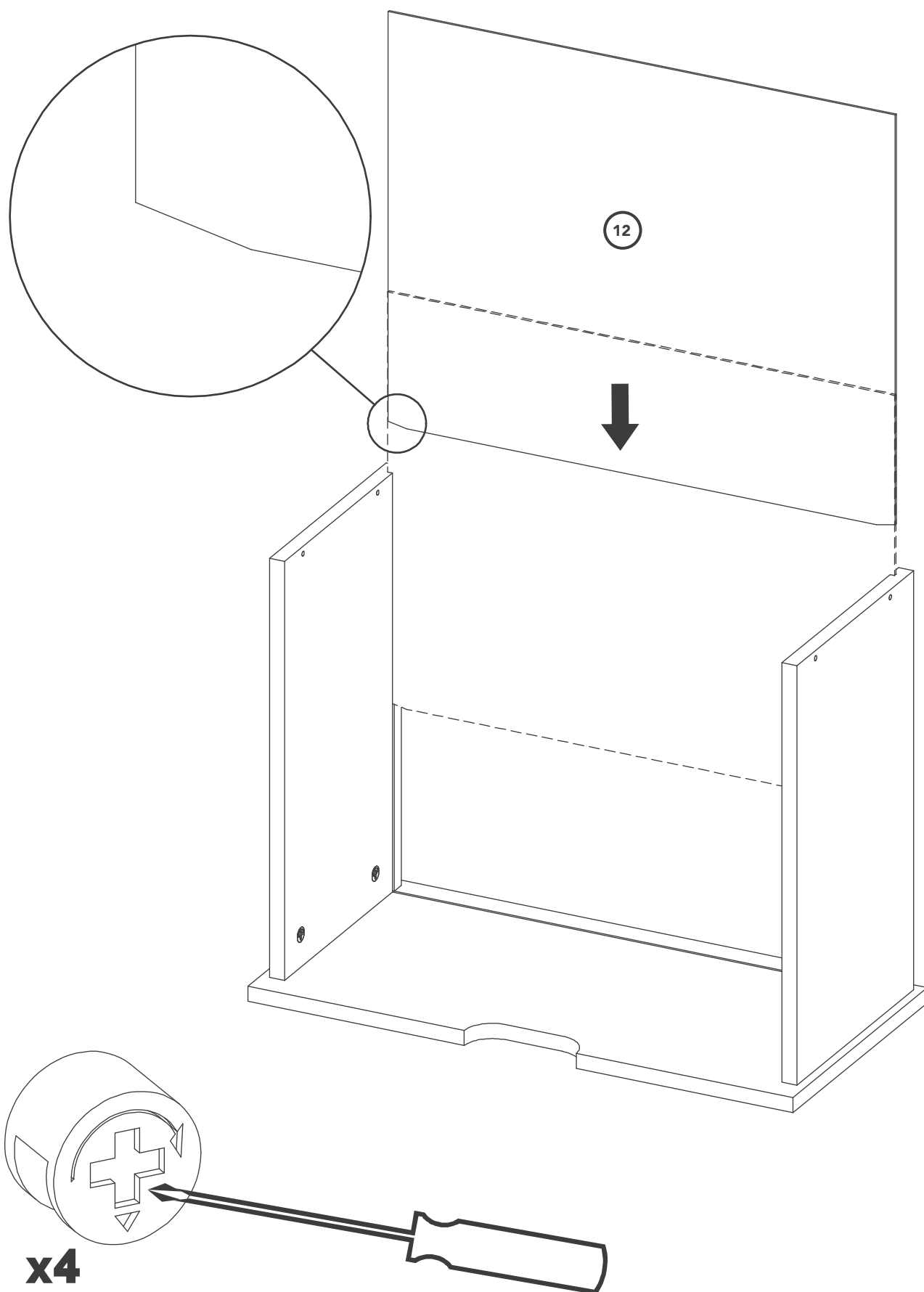

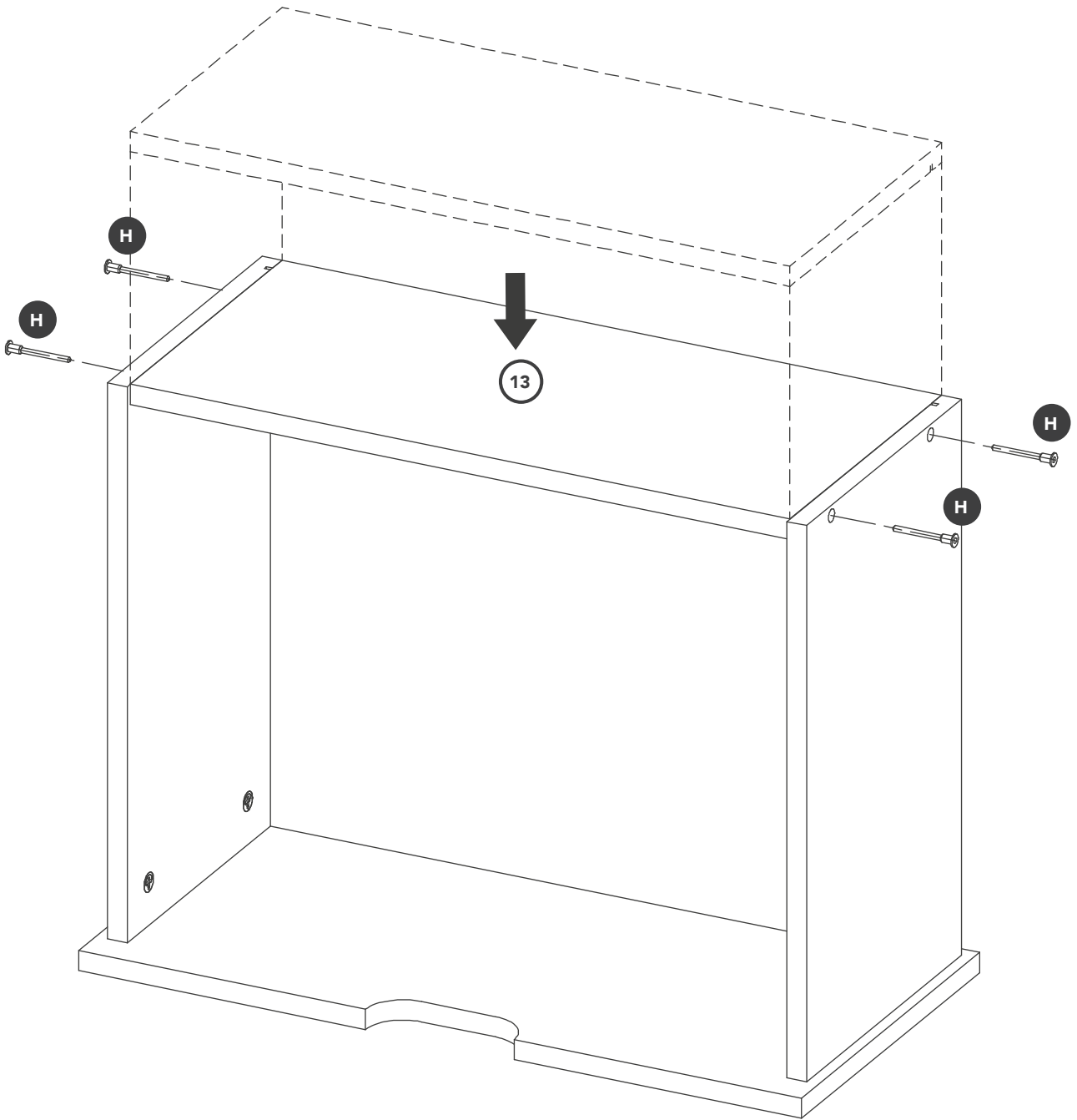

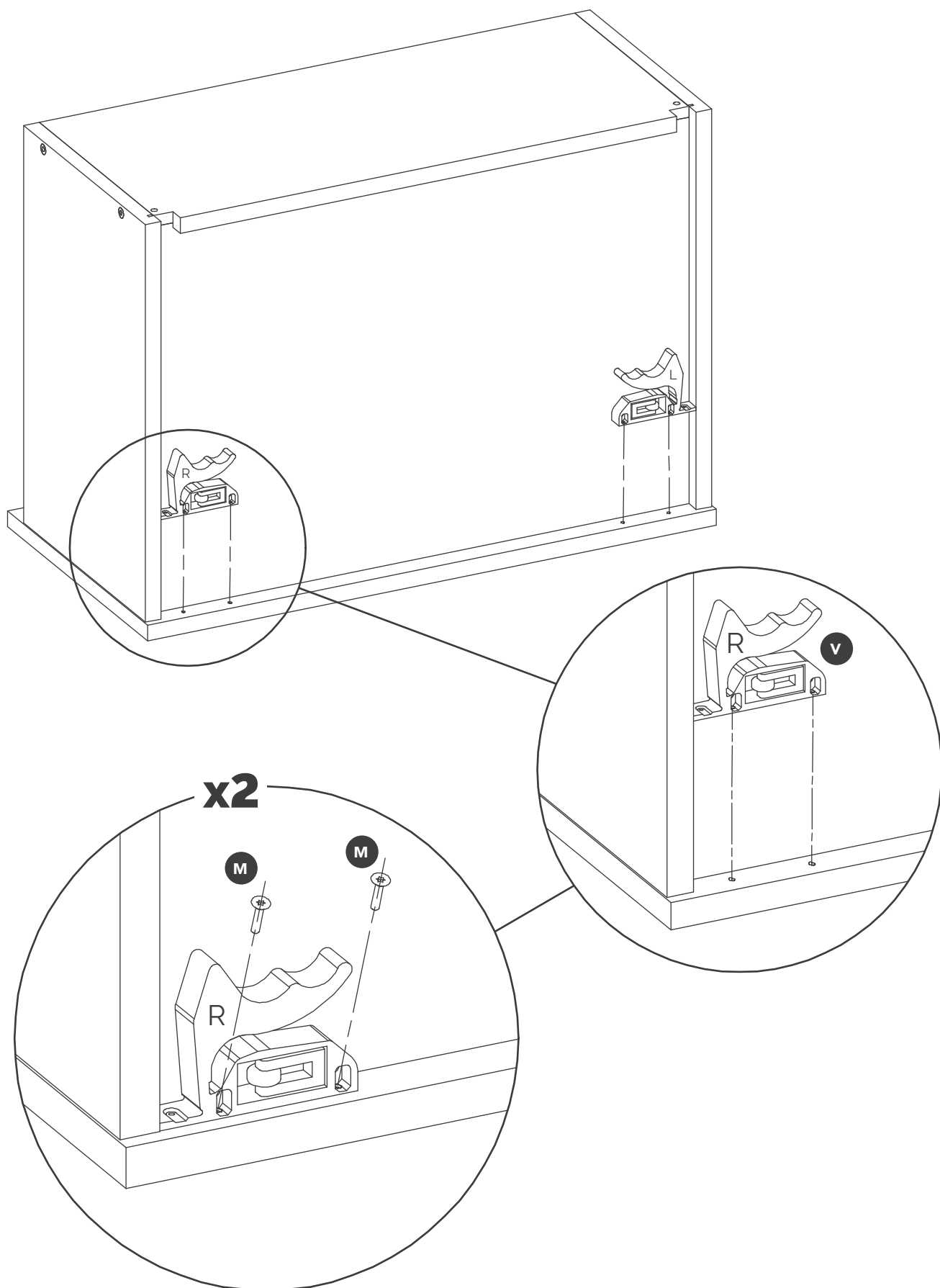

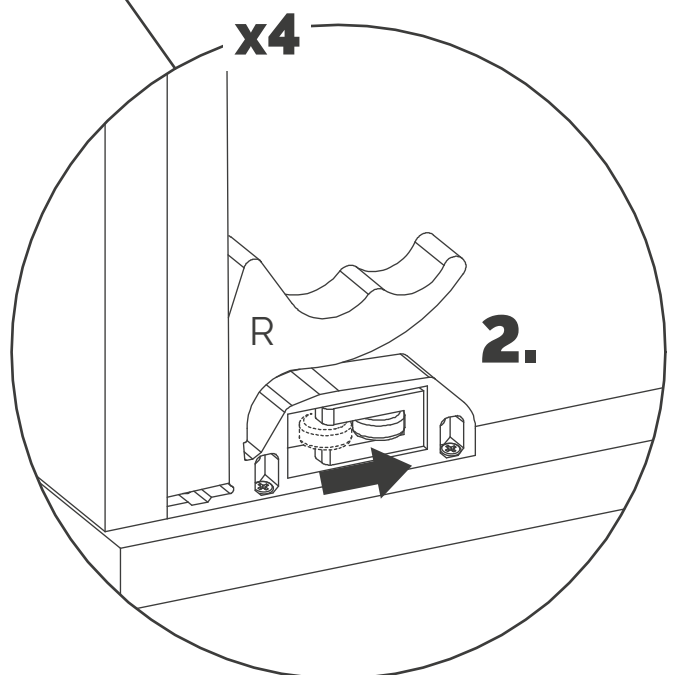
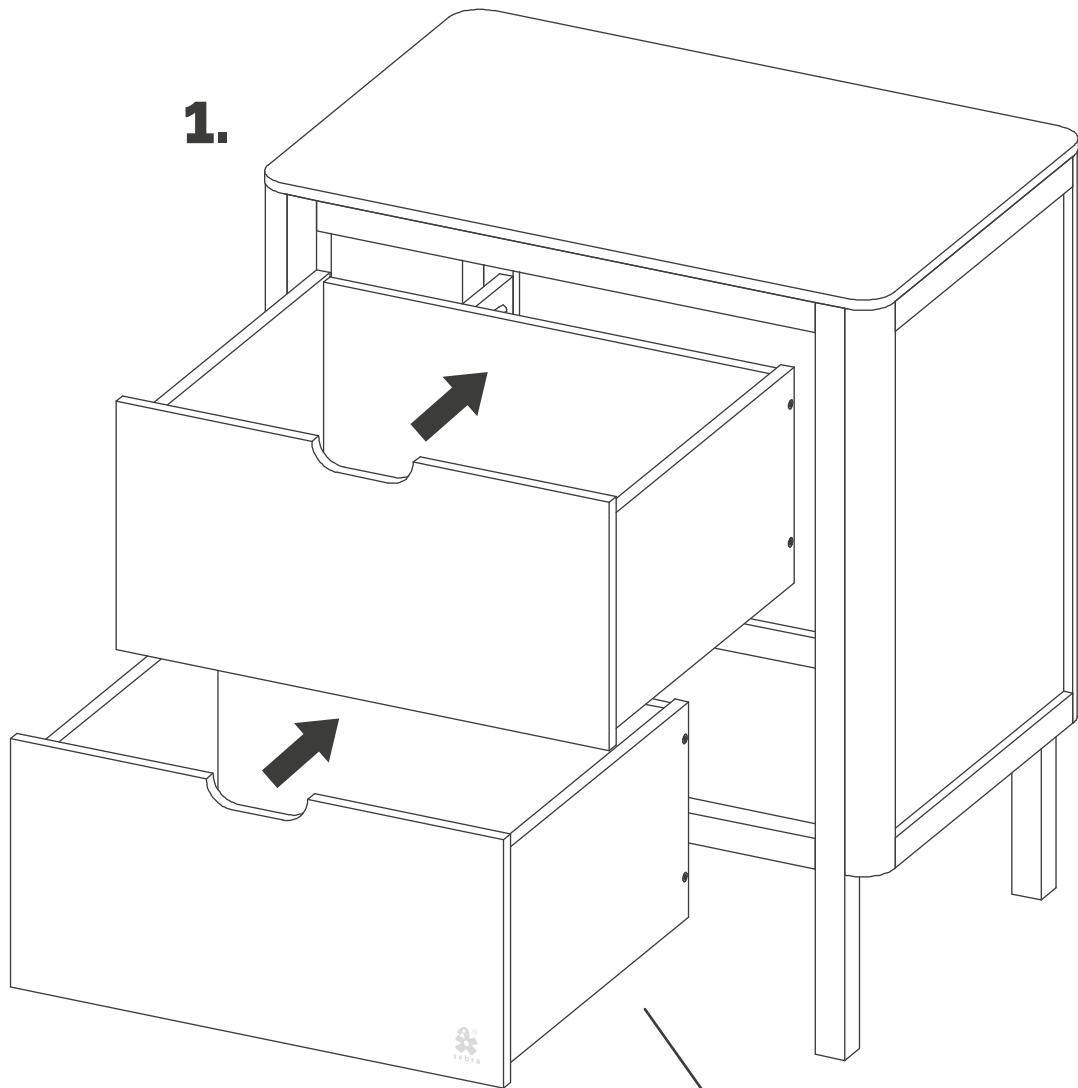

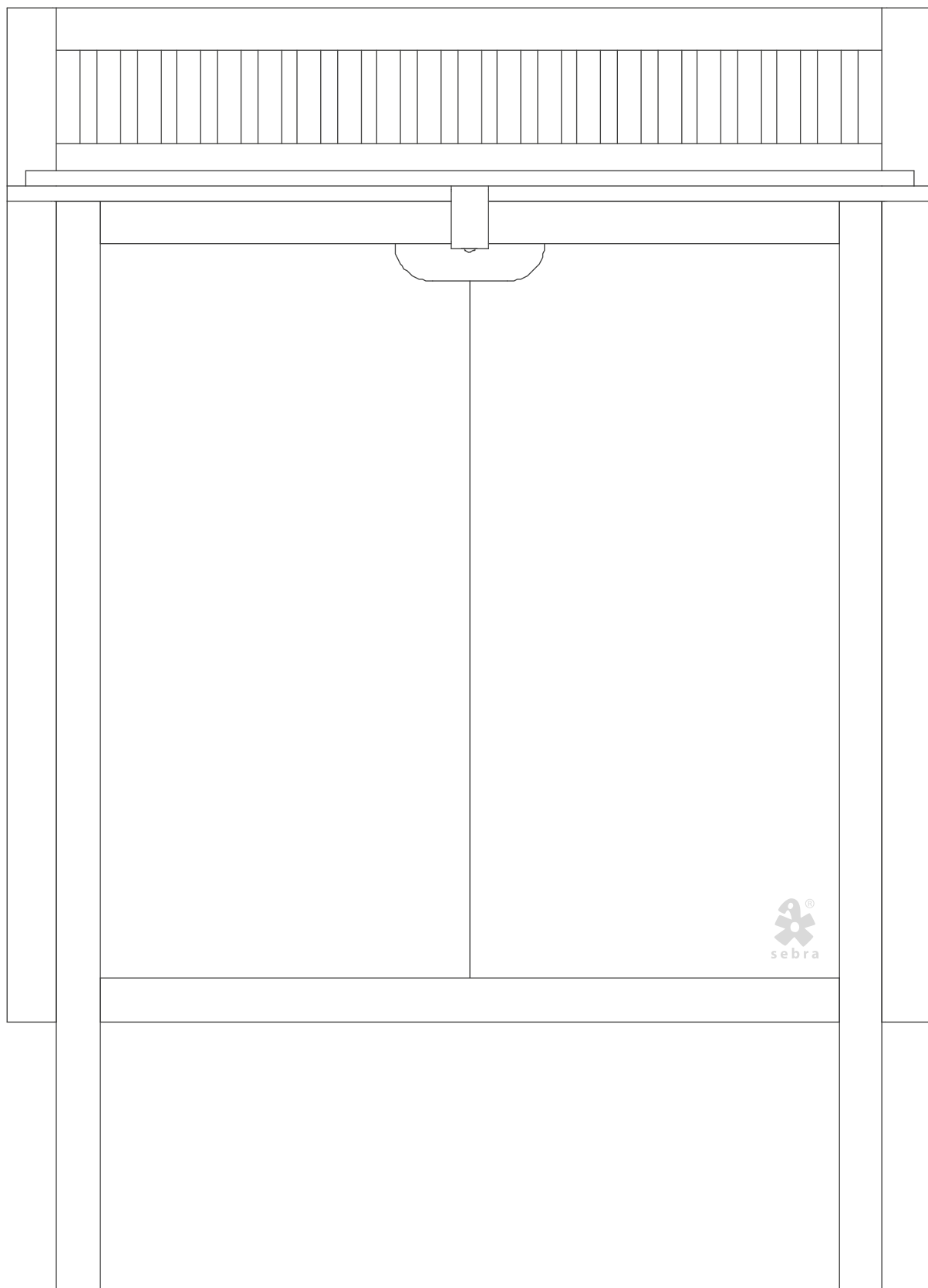

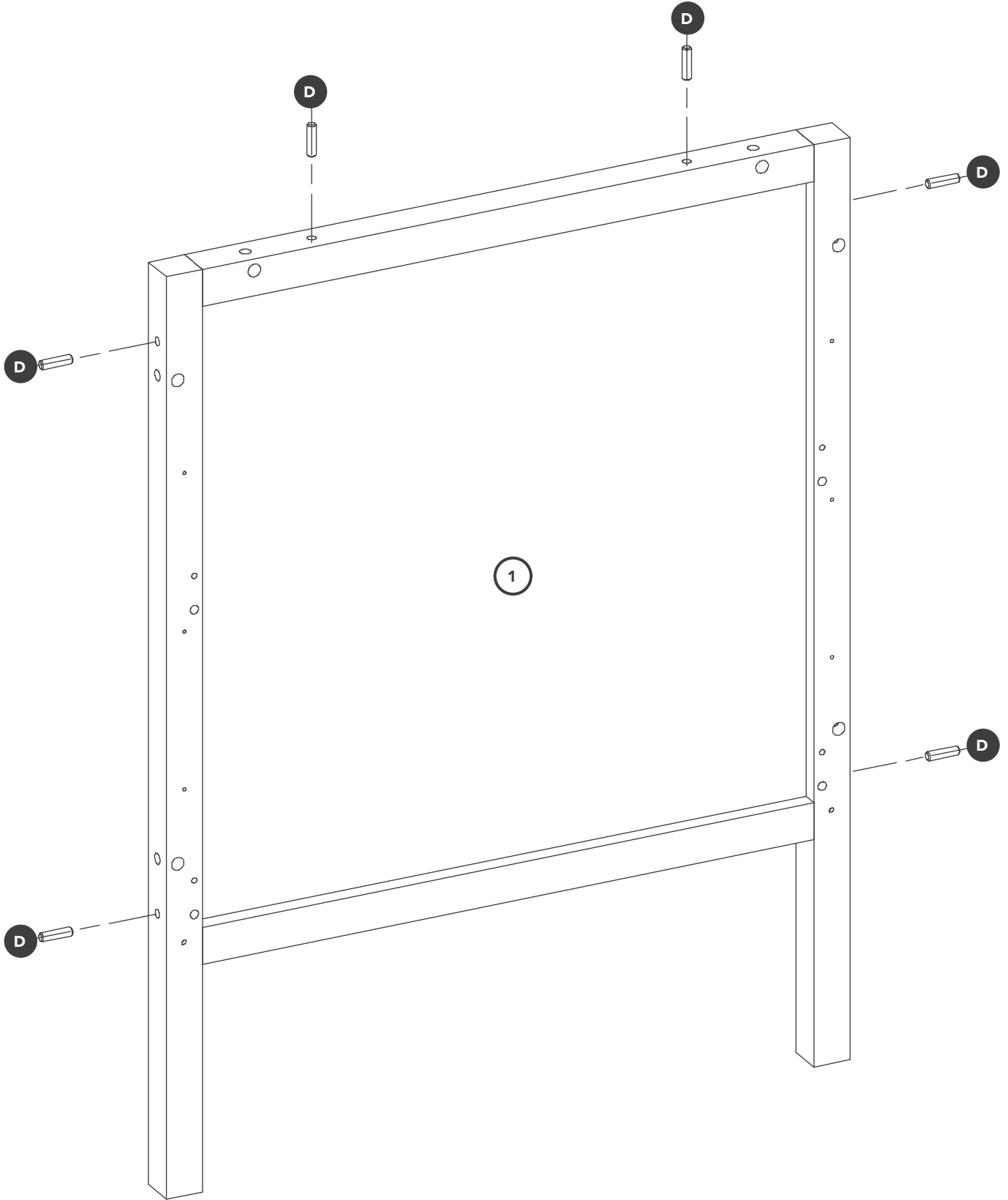

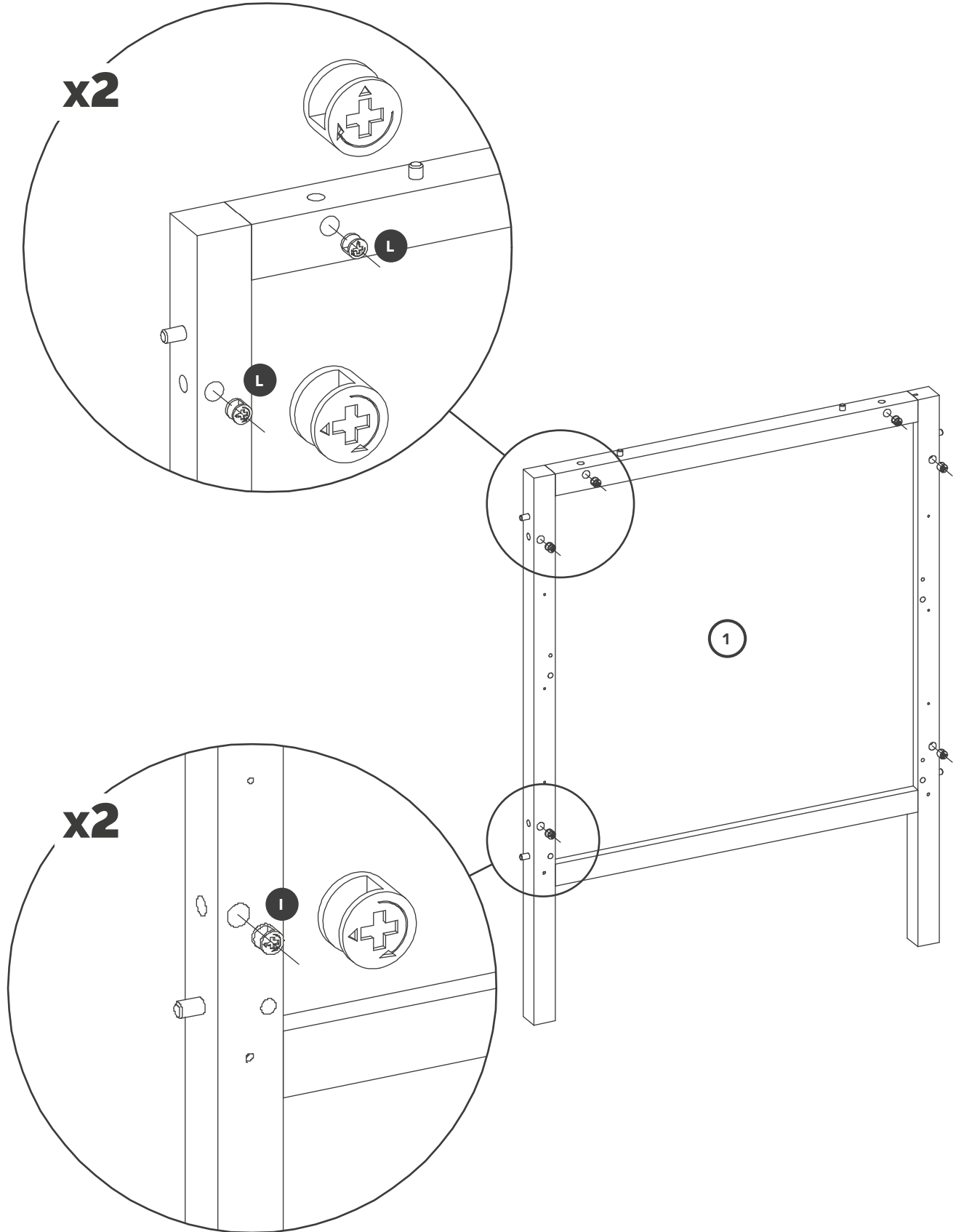

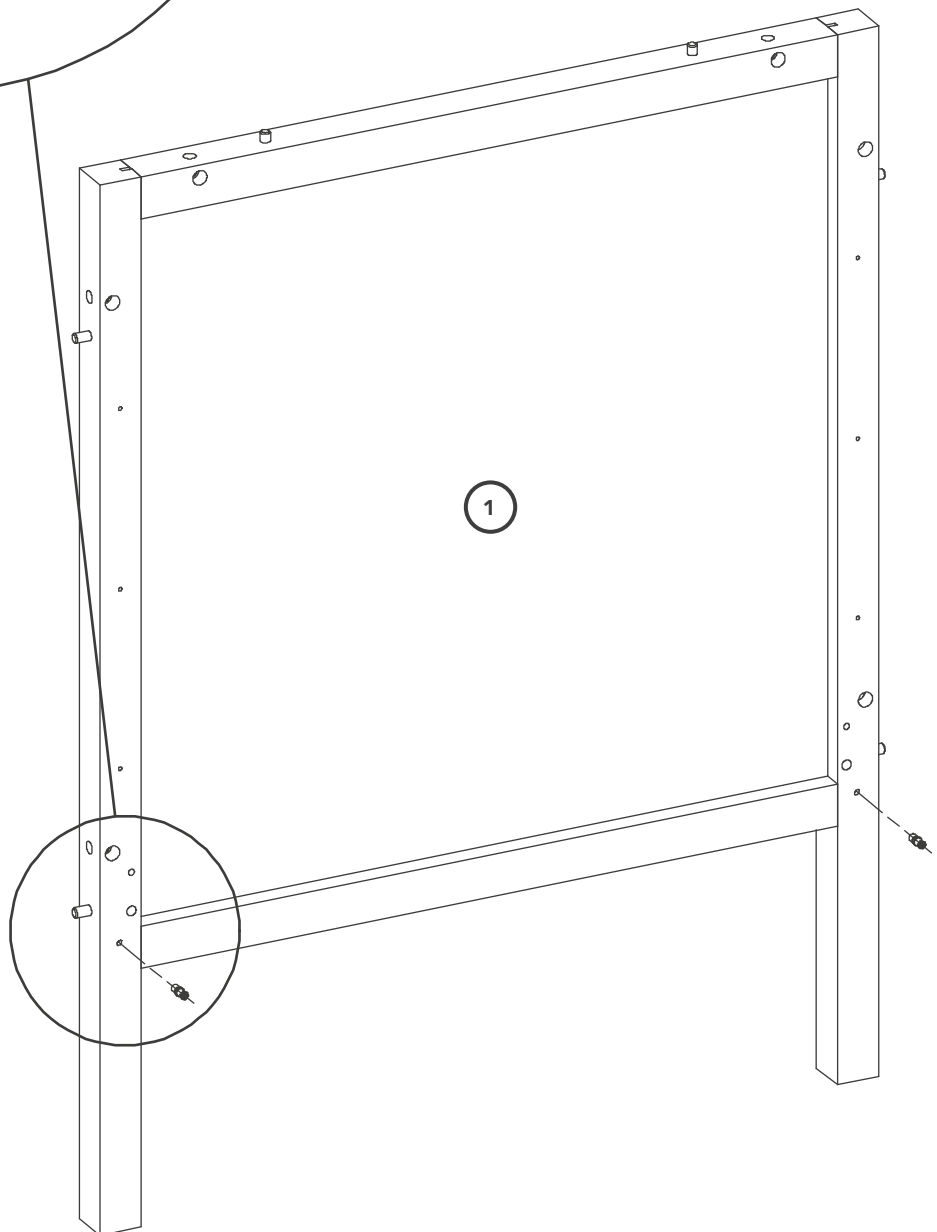
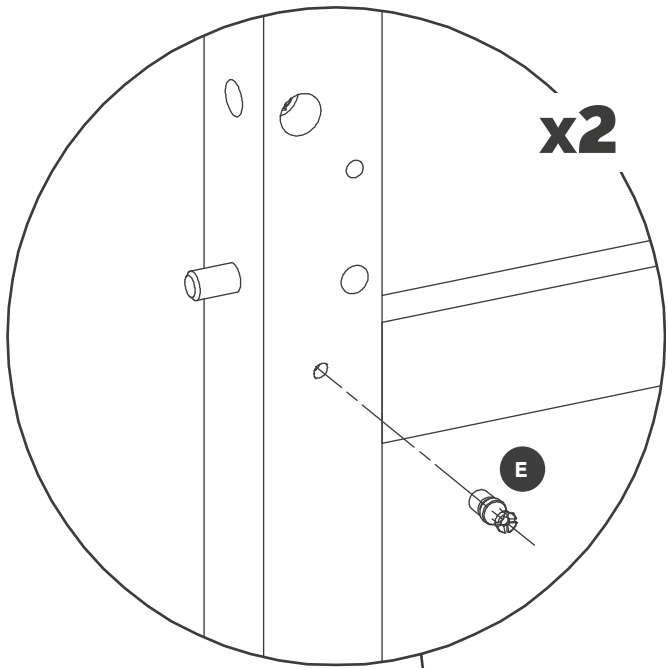

1

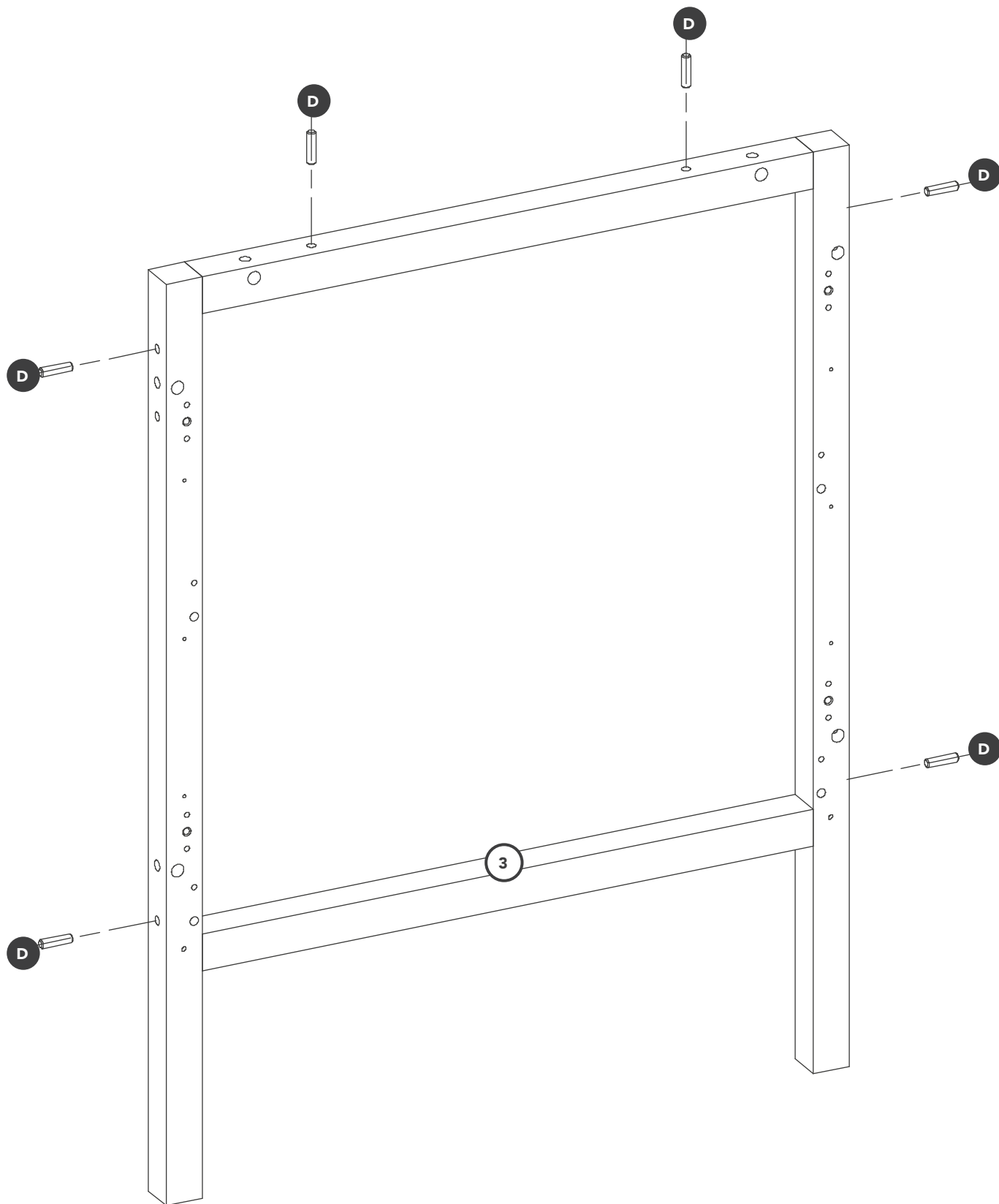

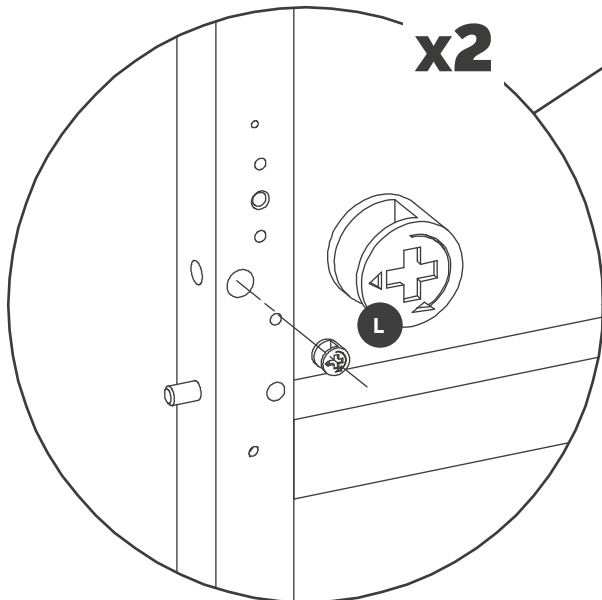
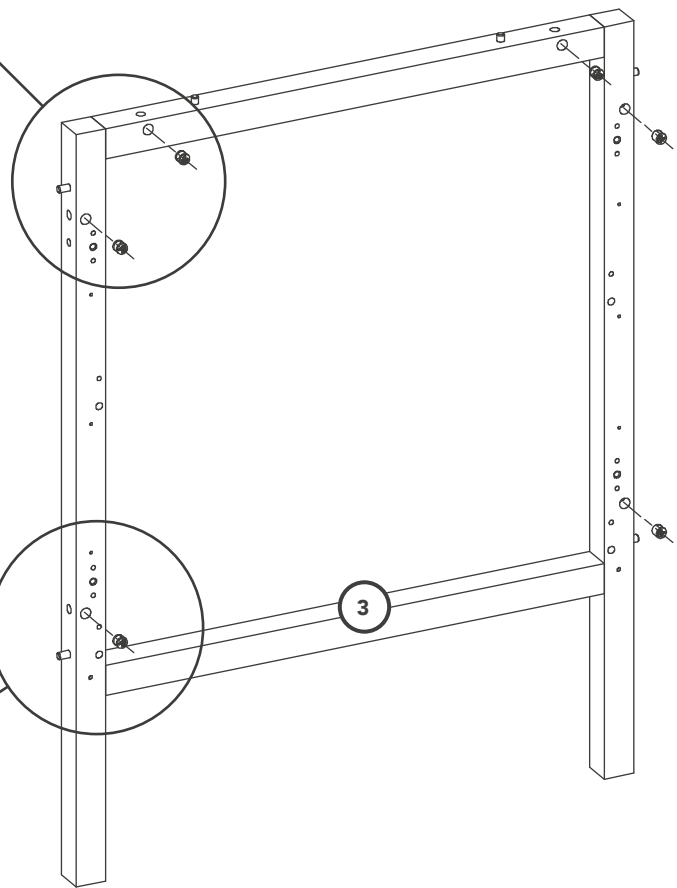
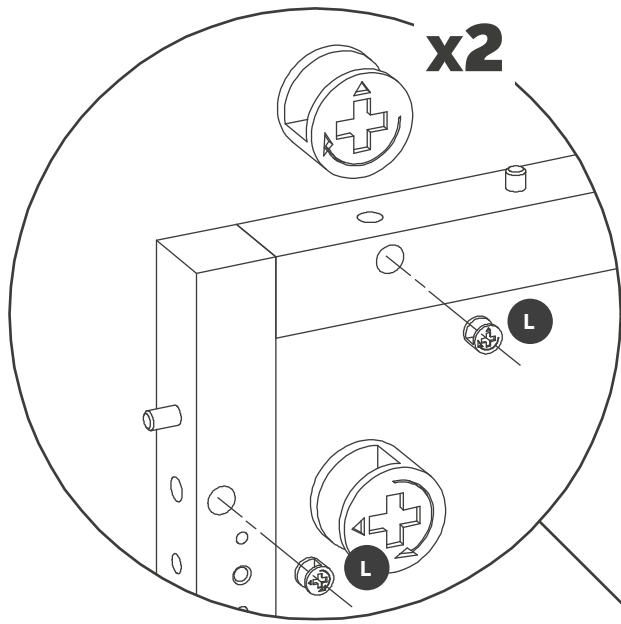

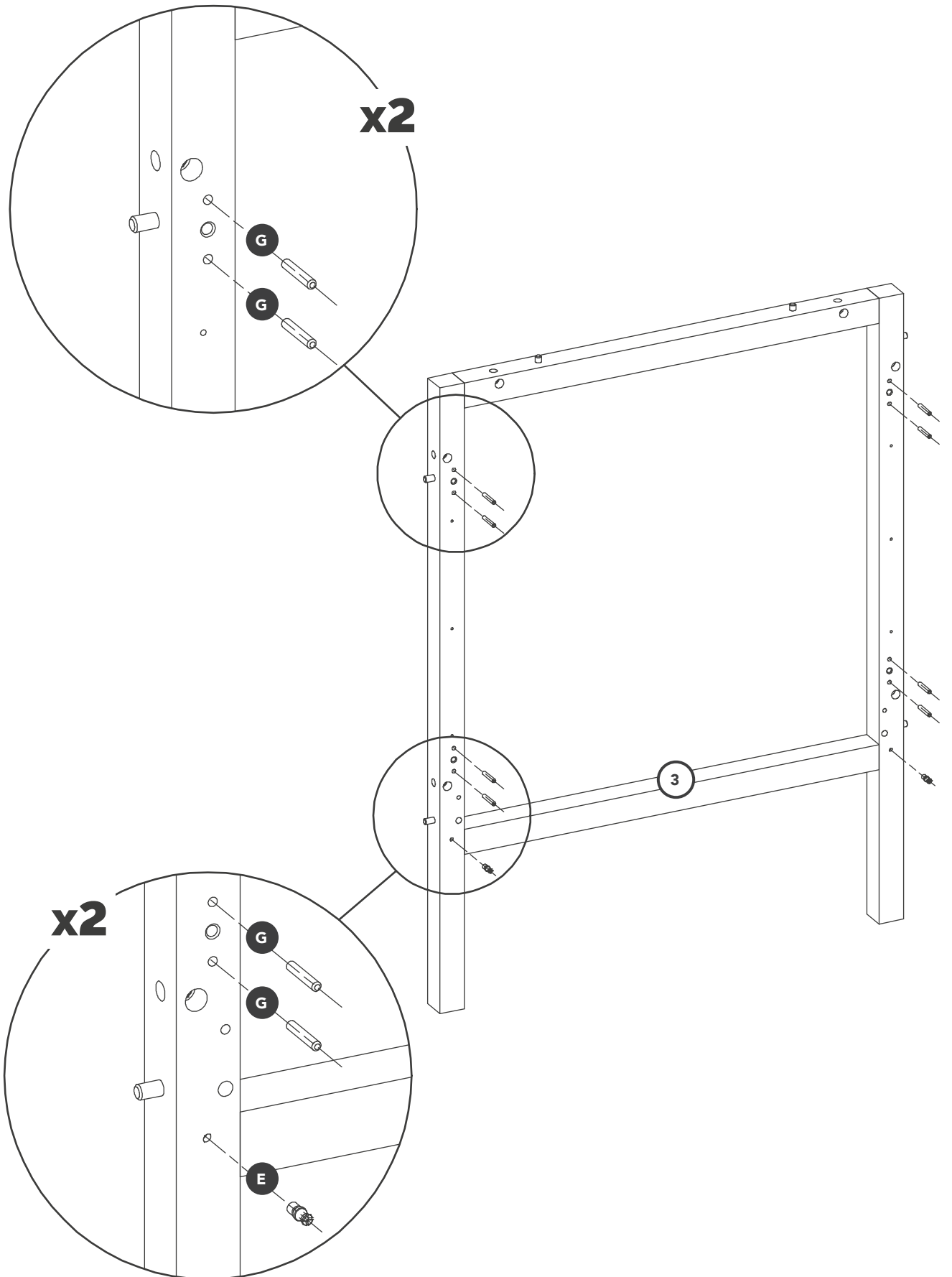

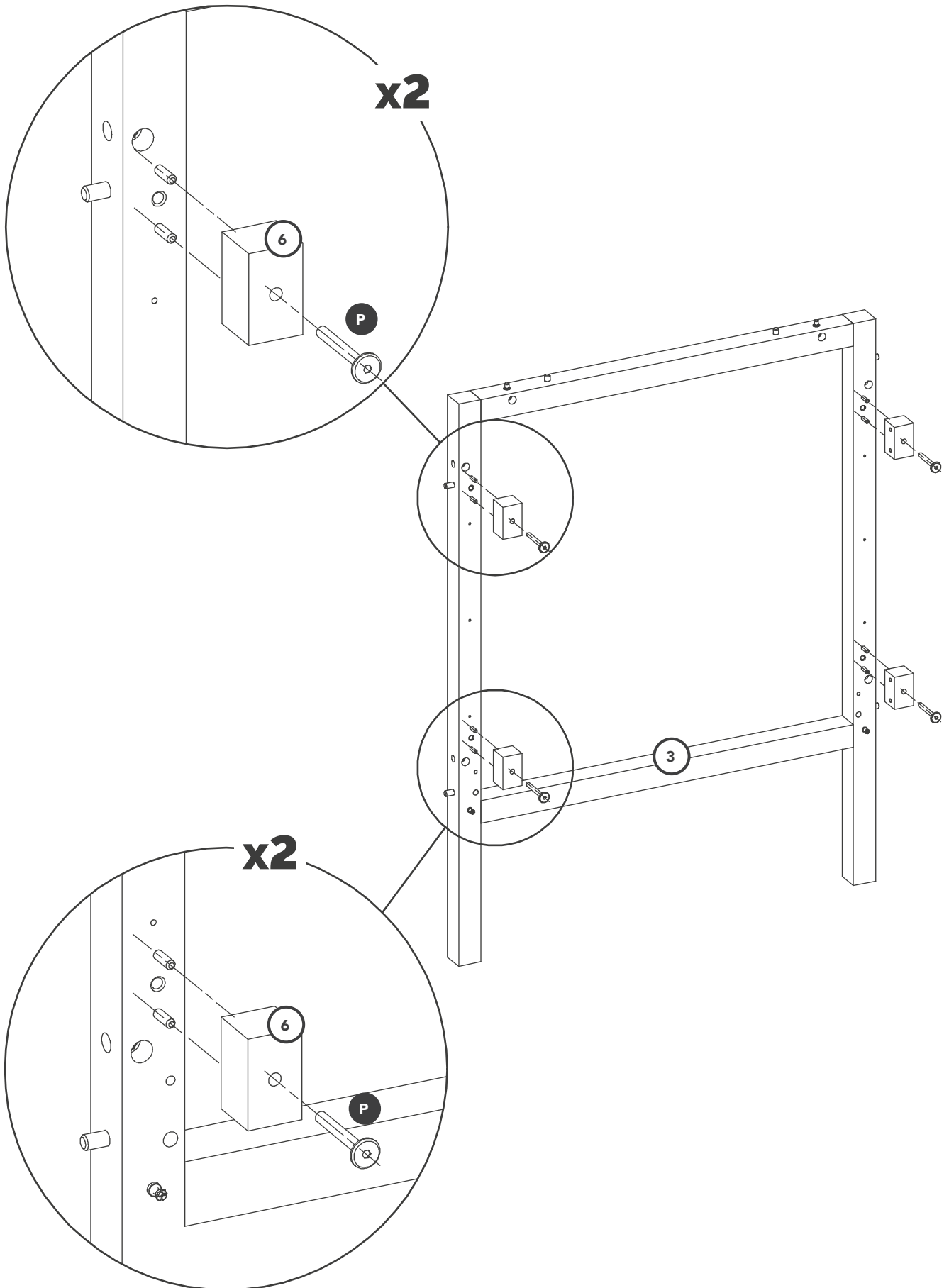

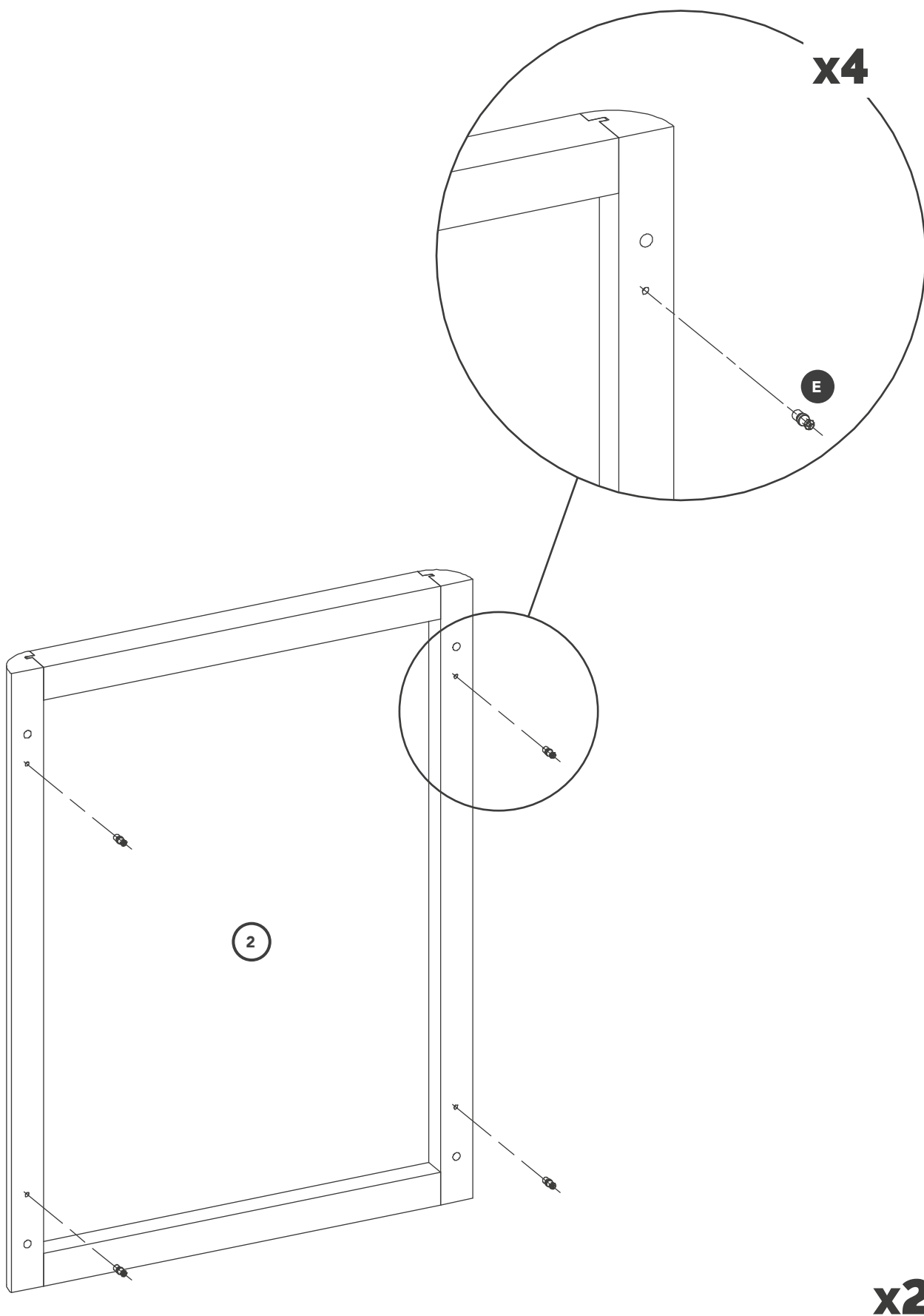

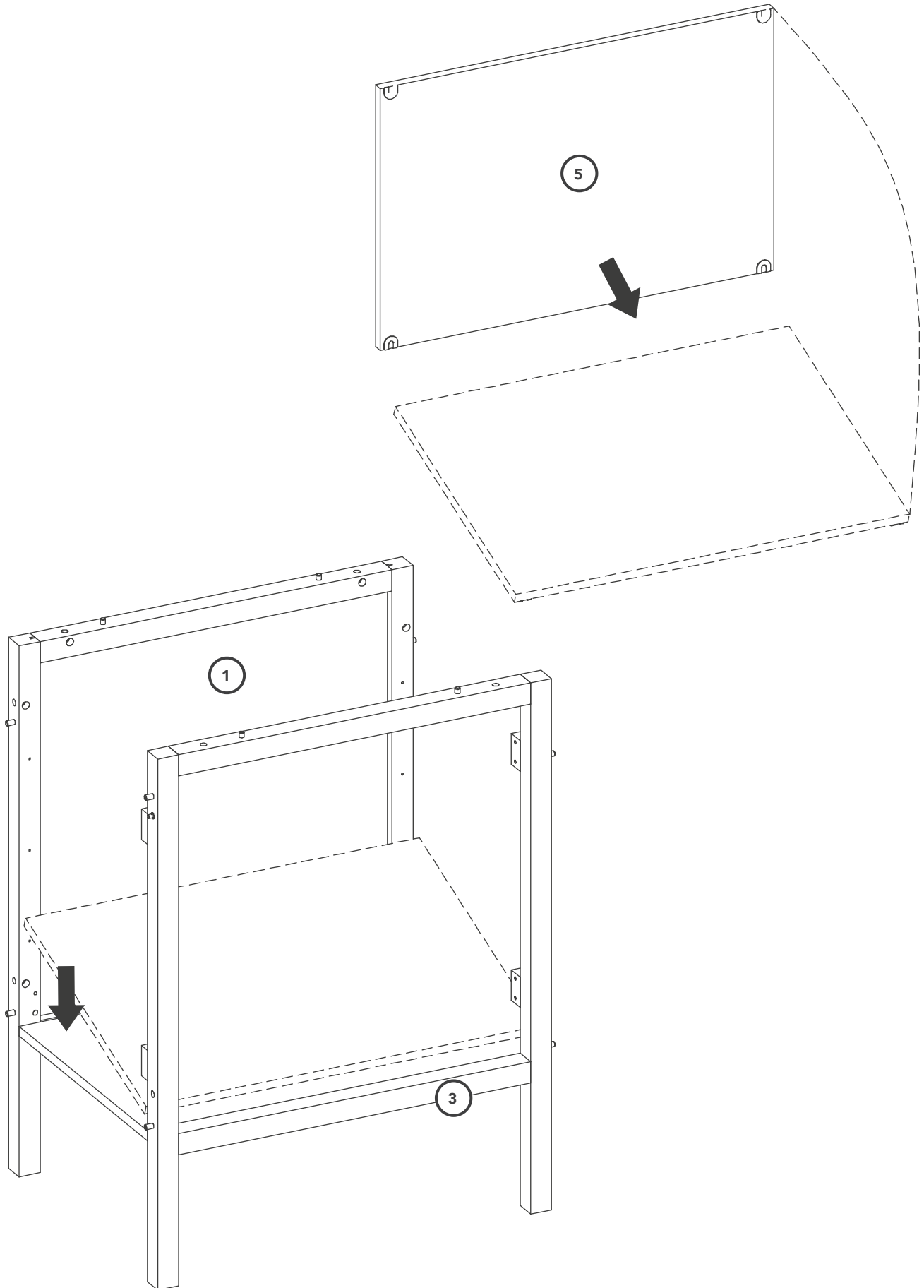

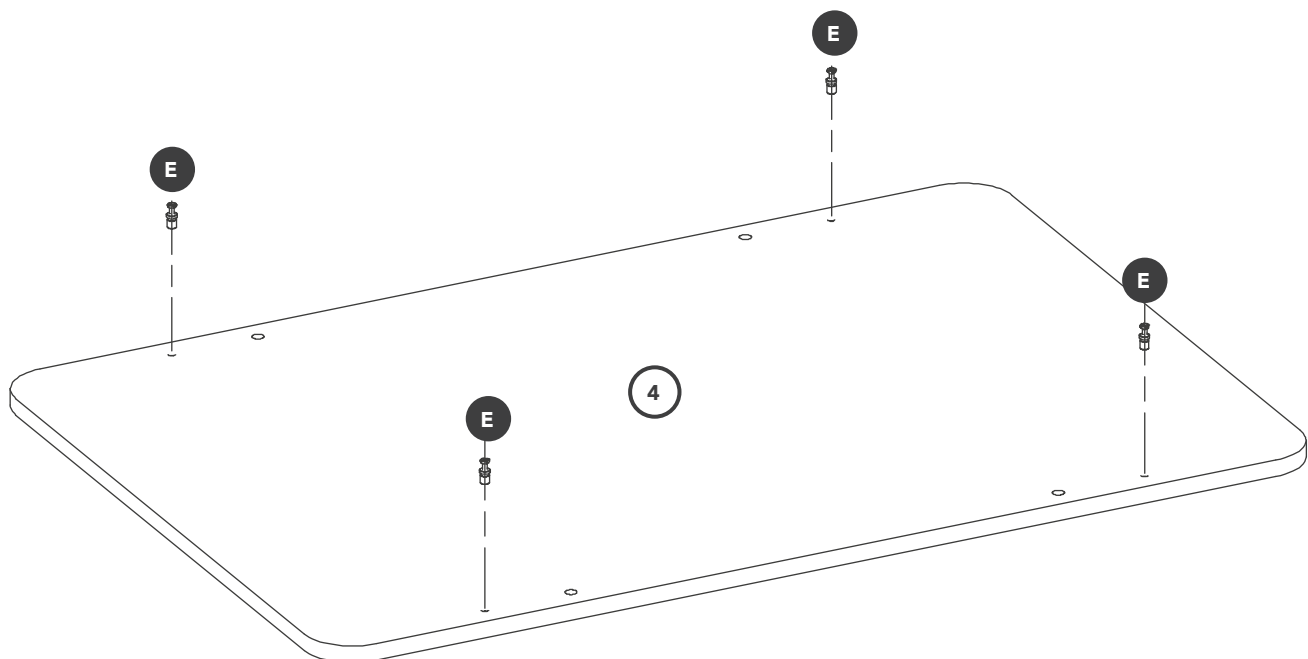
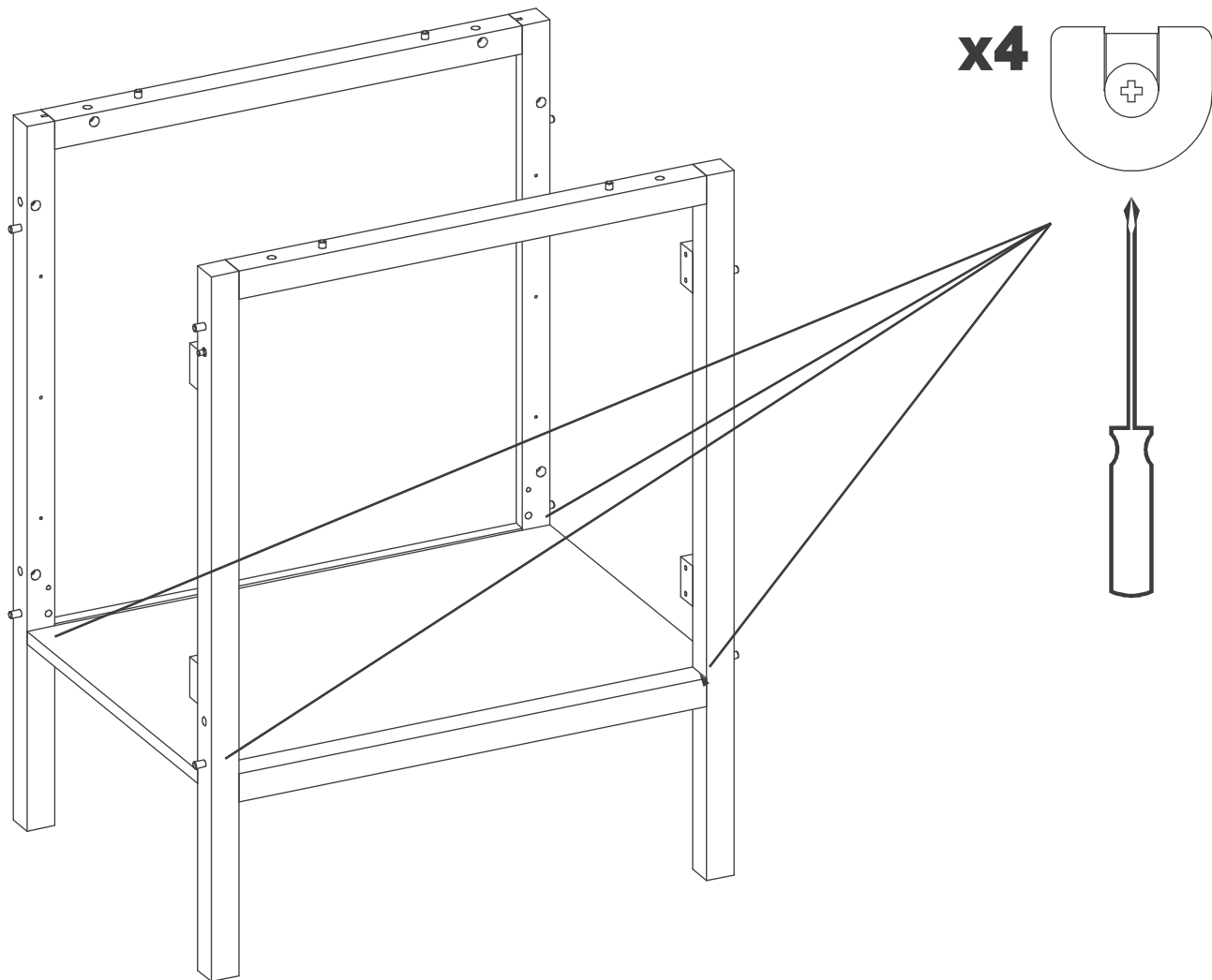

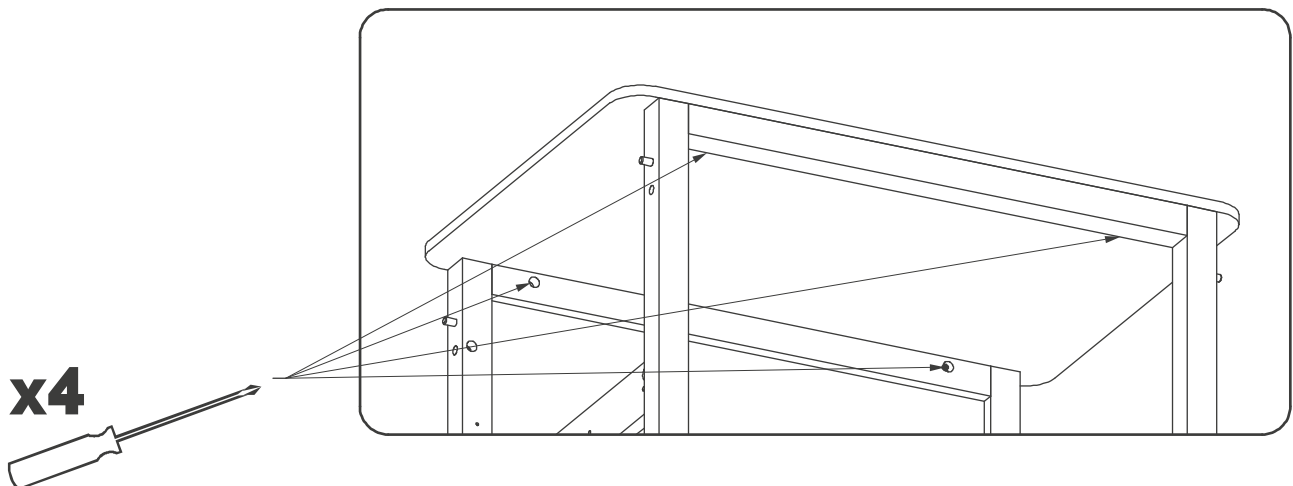
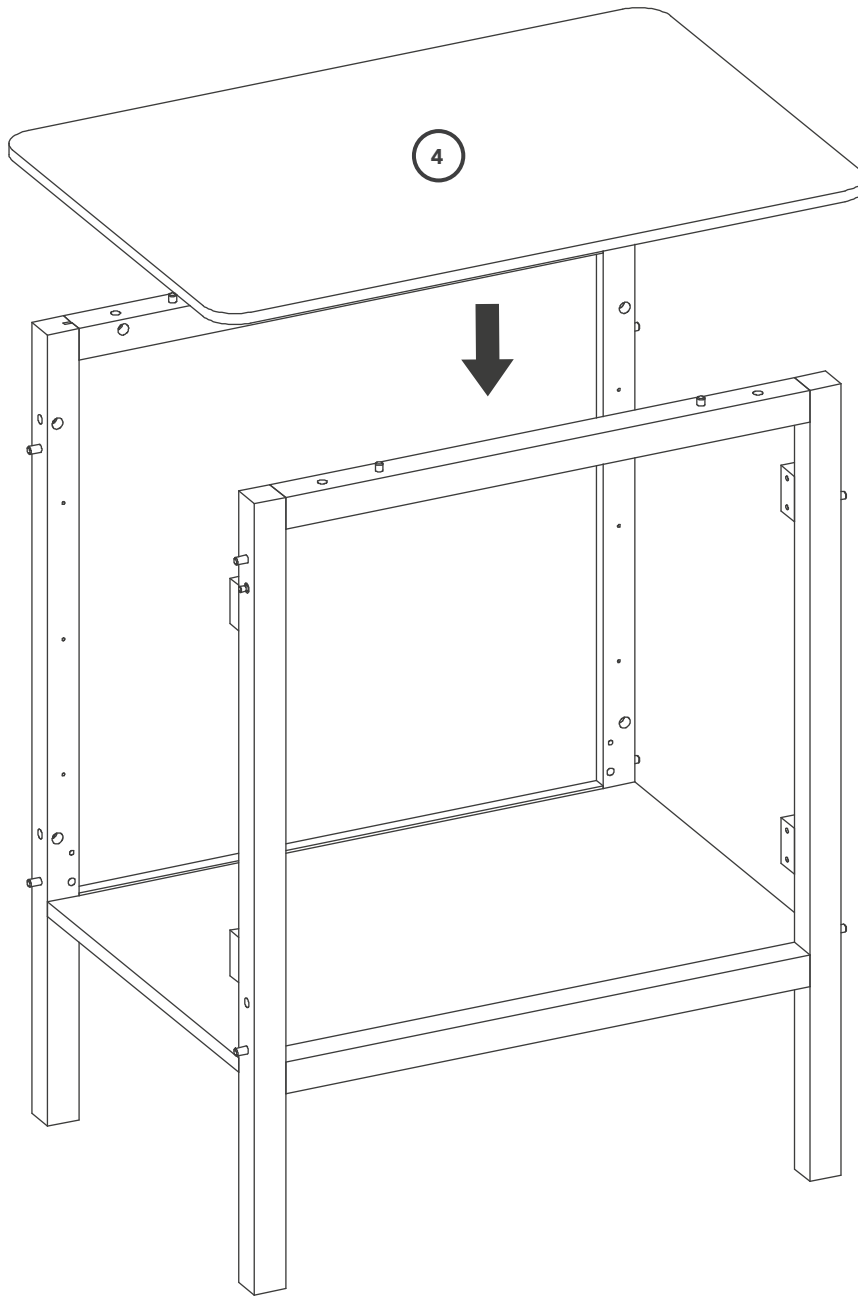

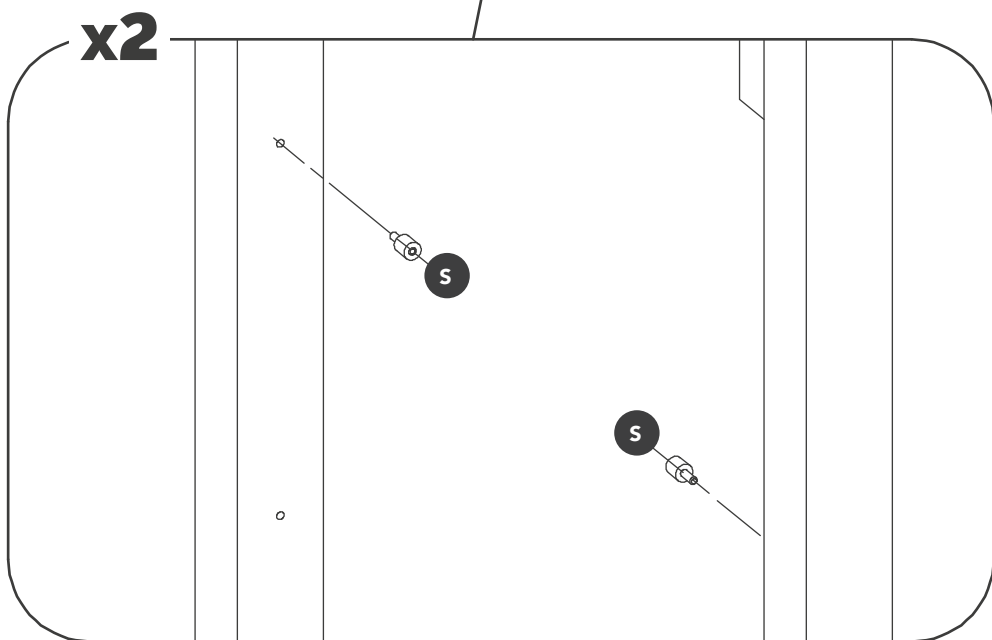
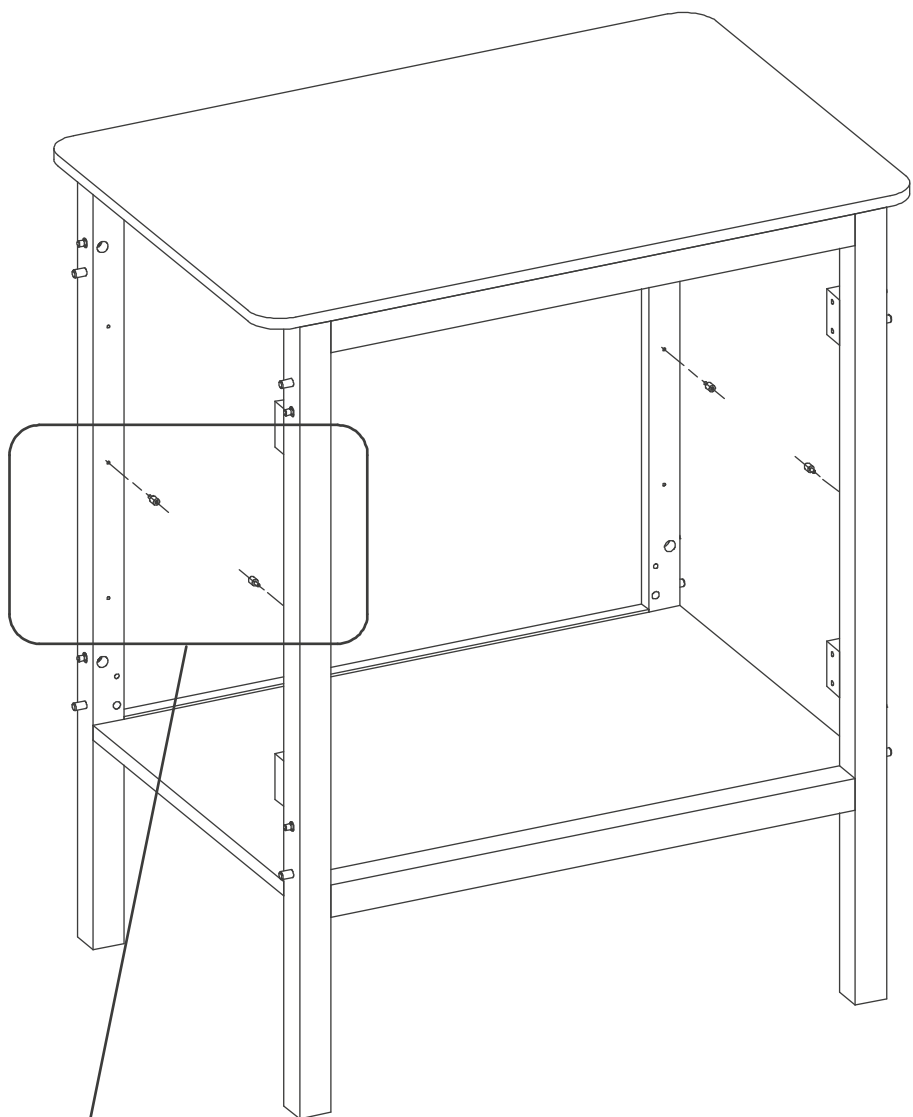

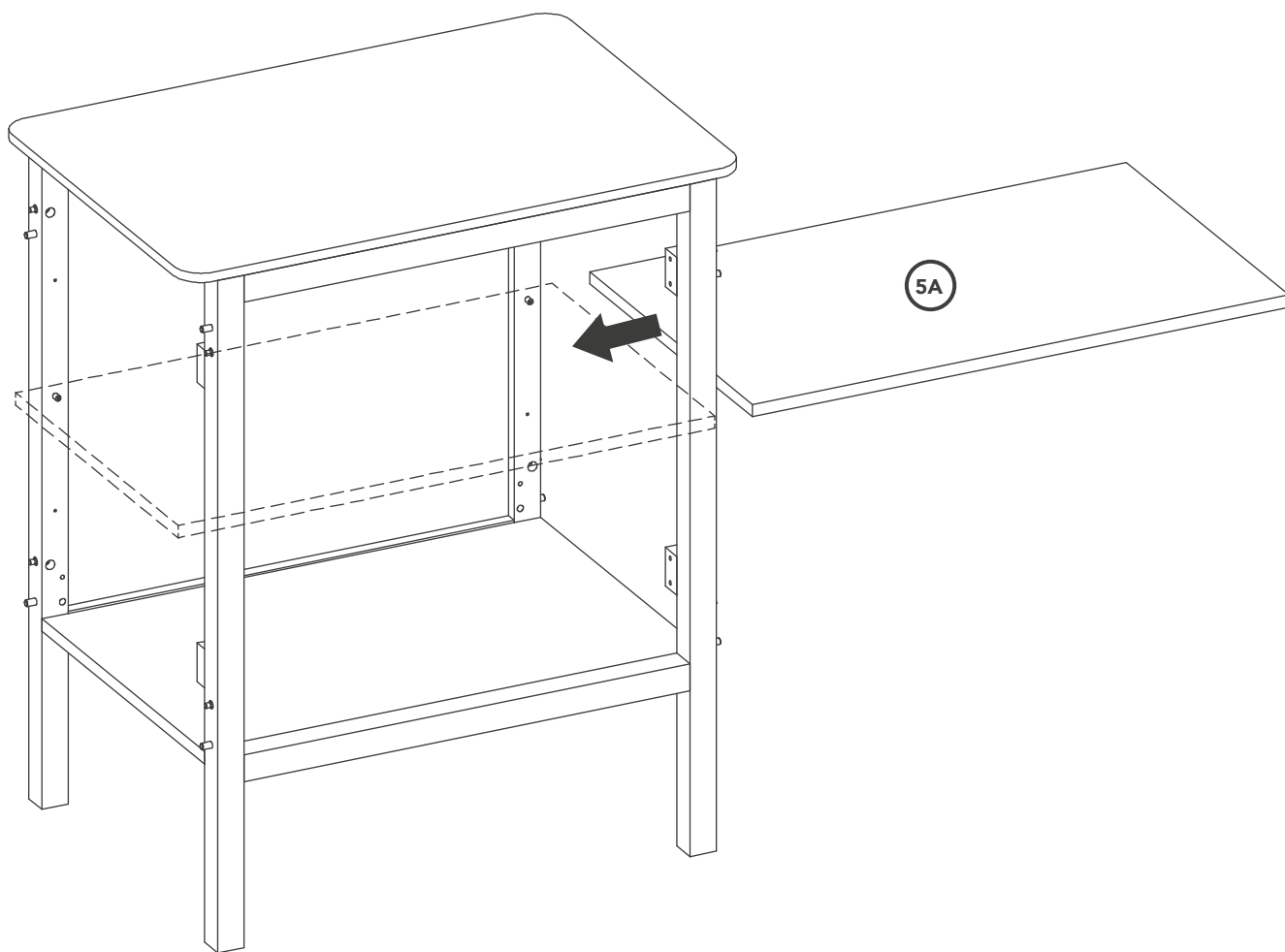



x4

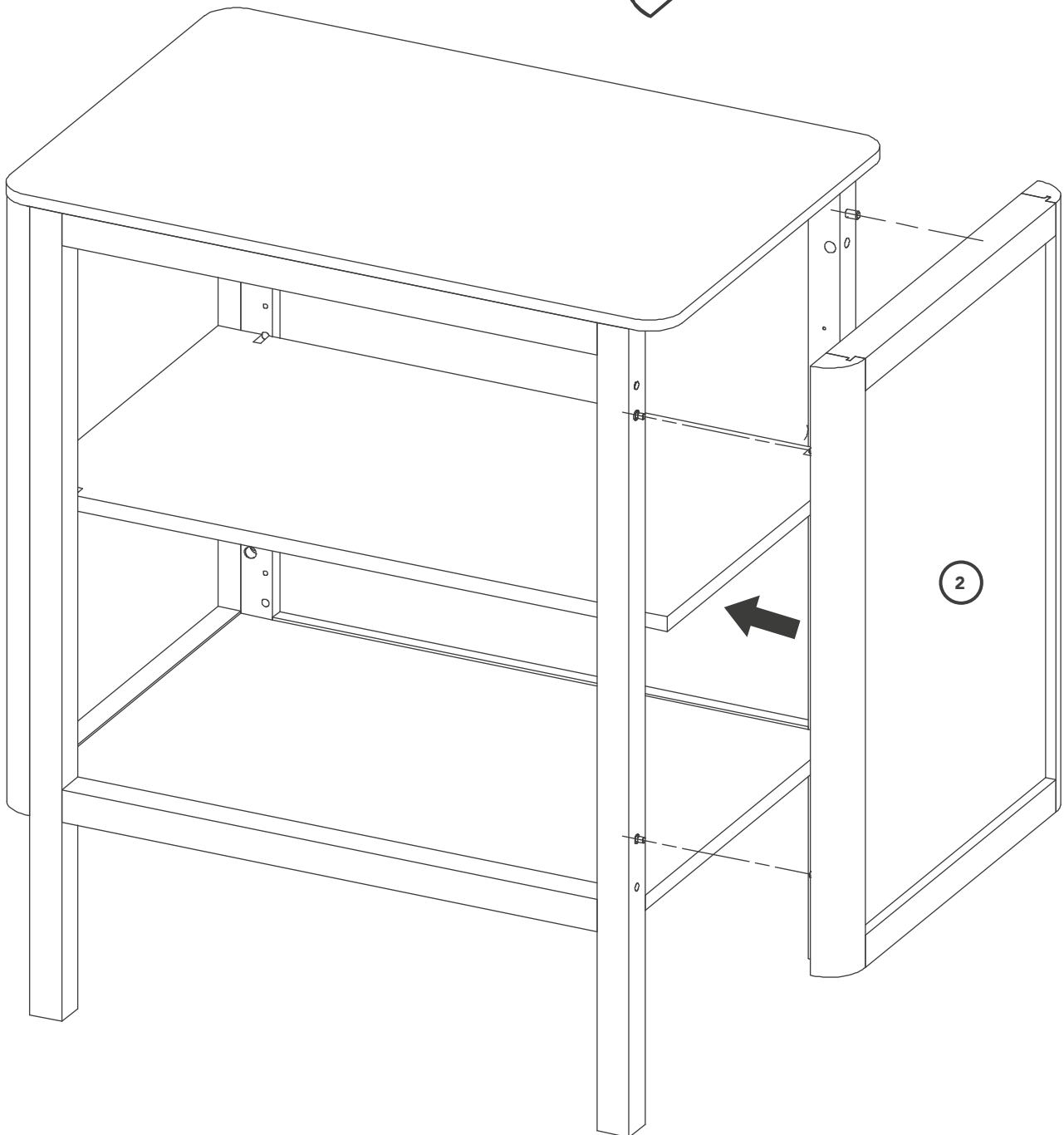
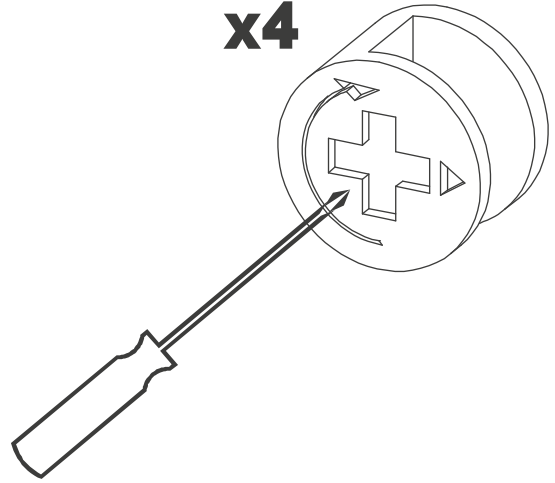

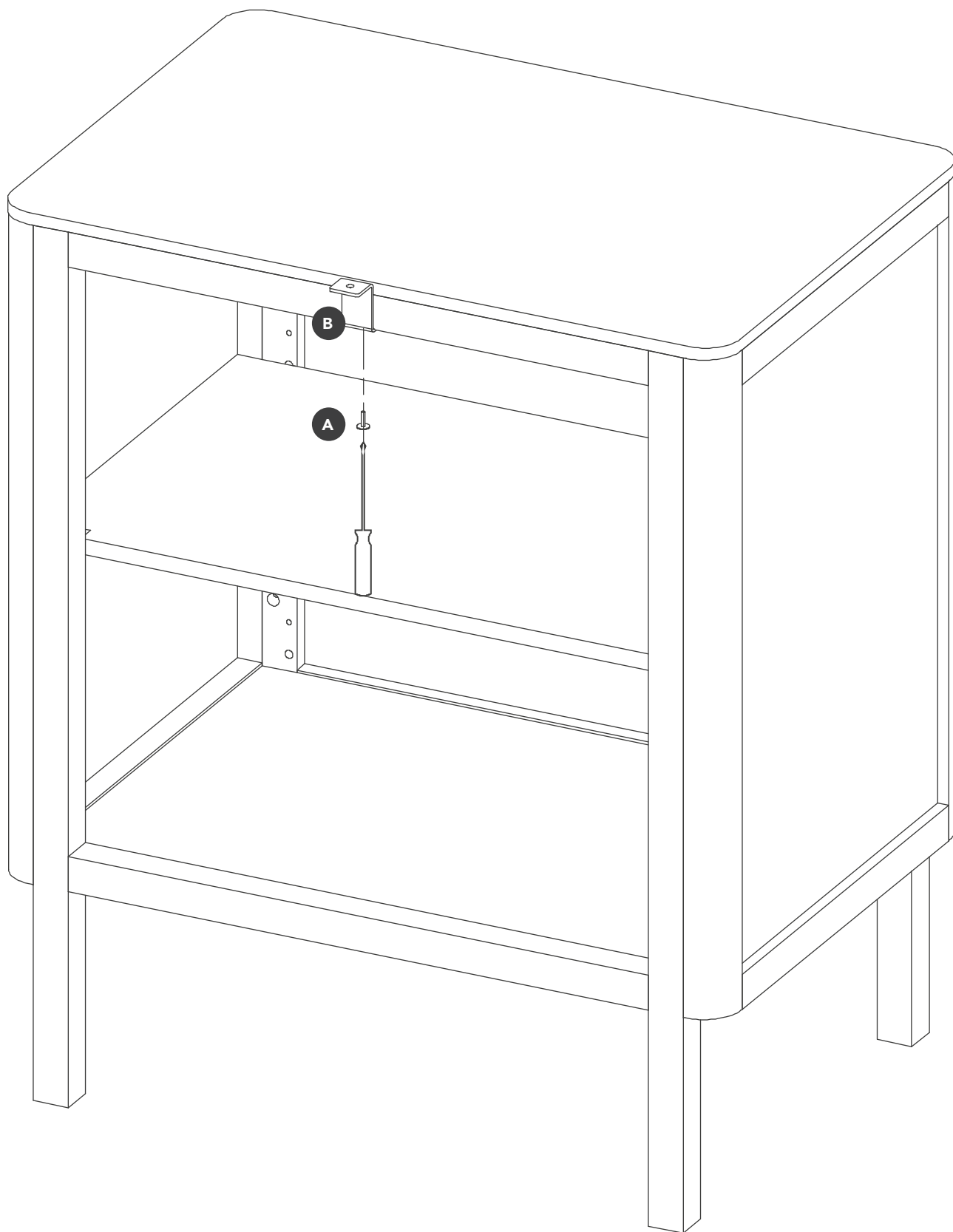

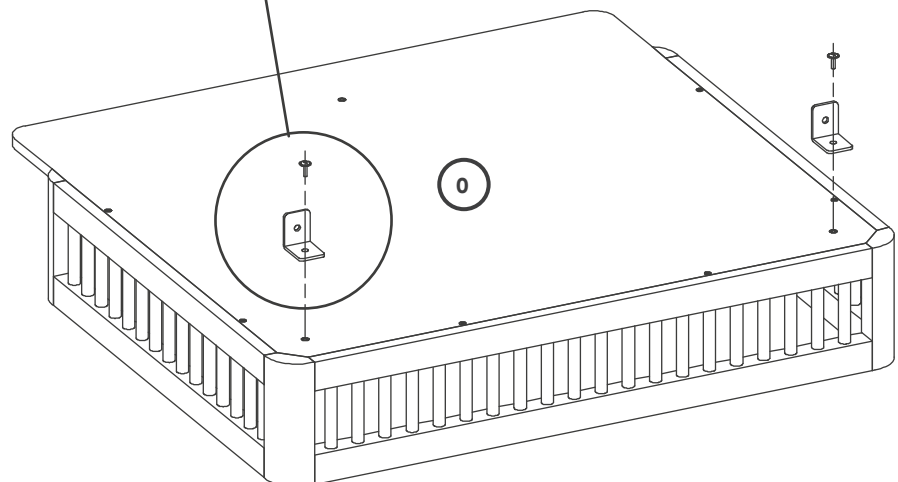
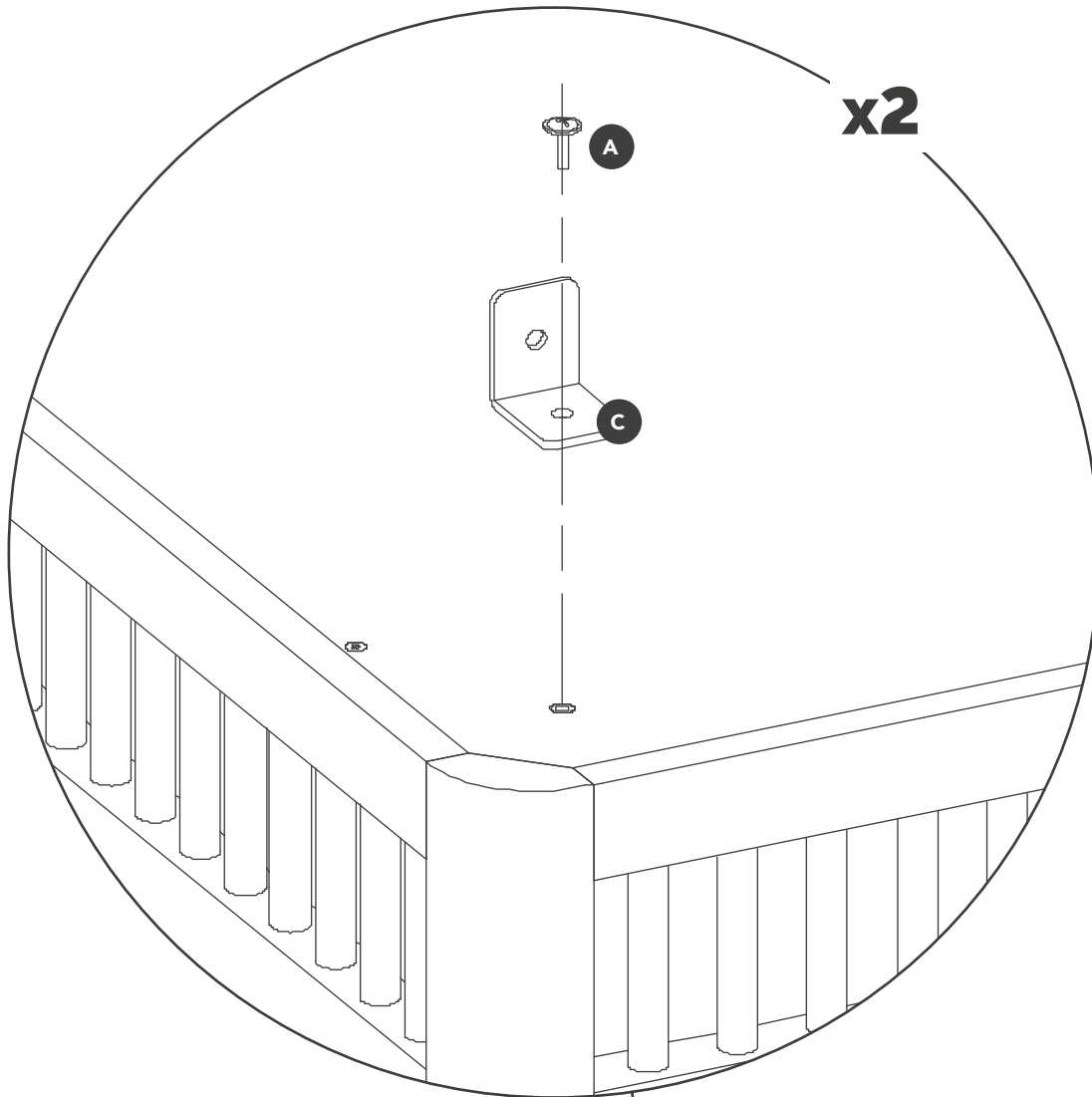

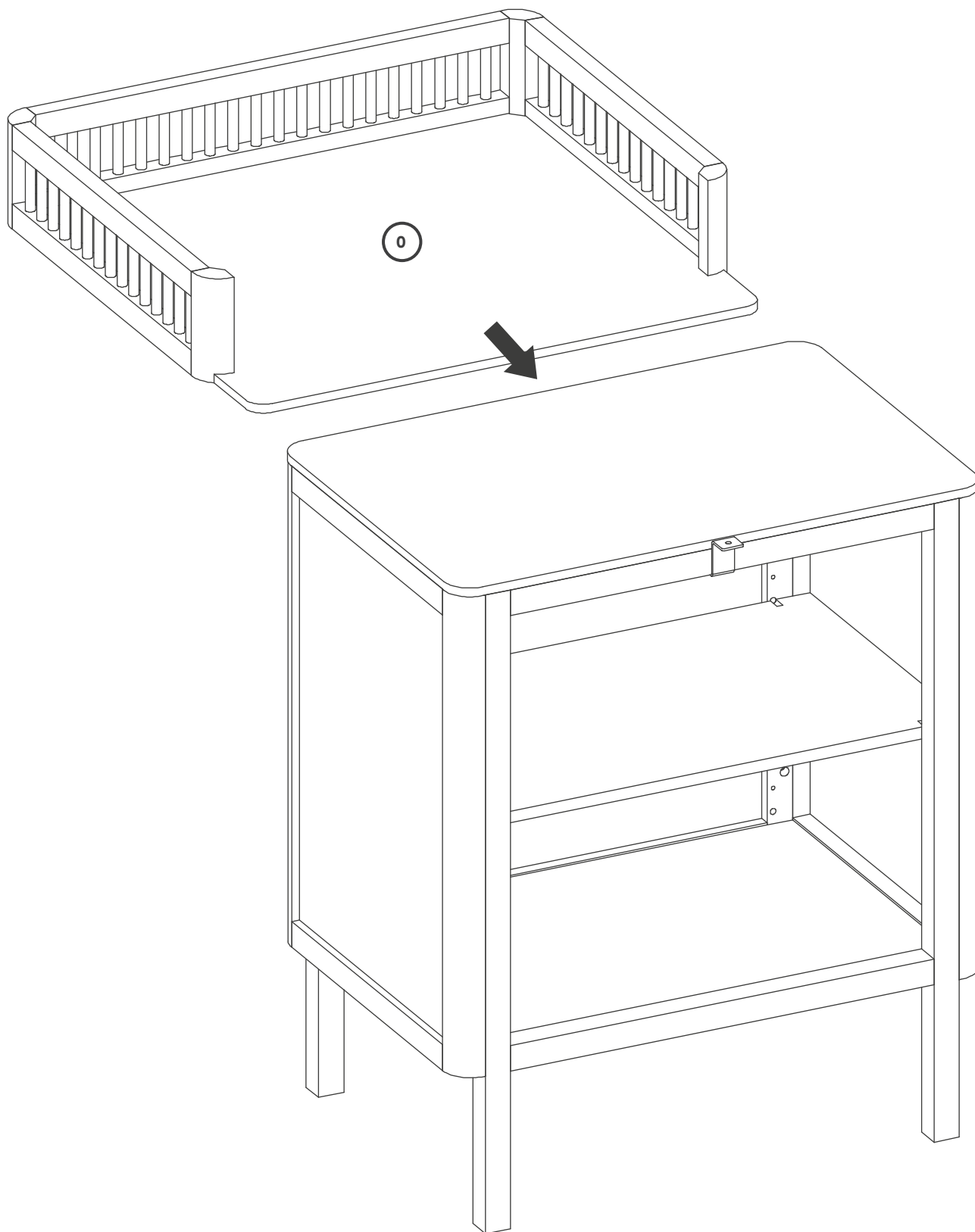

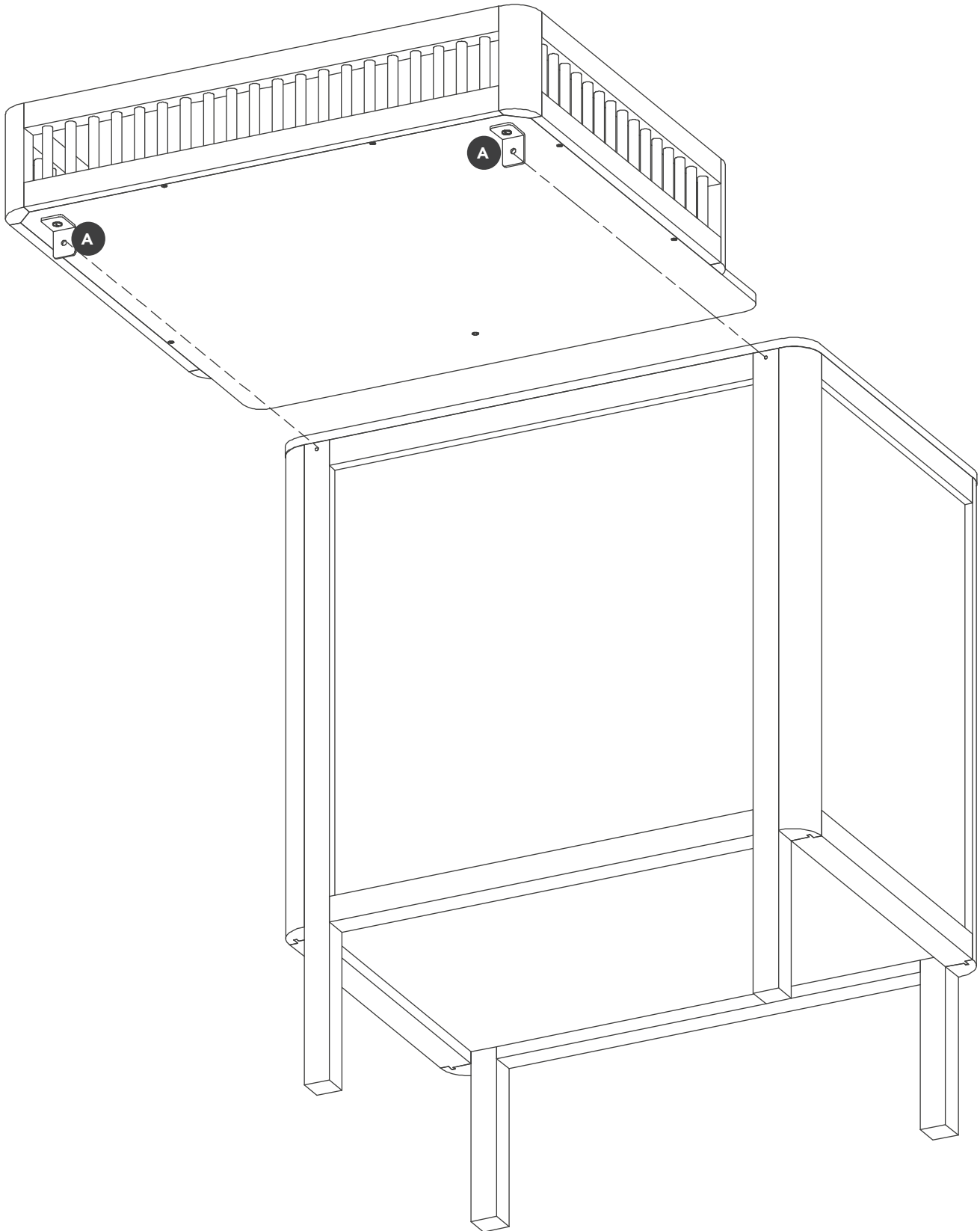

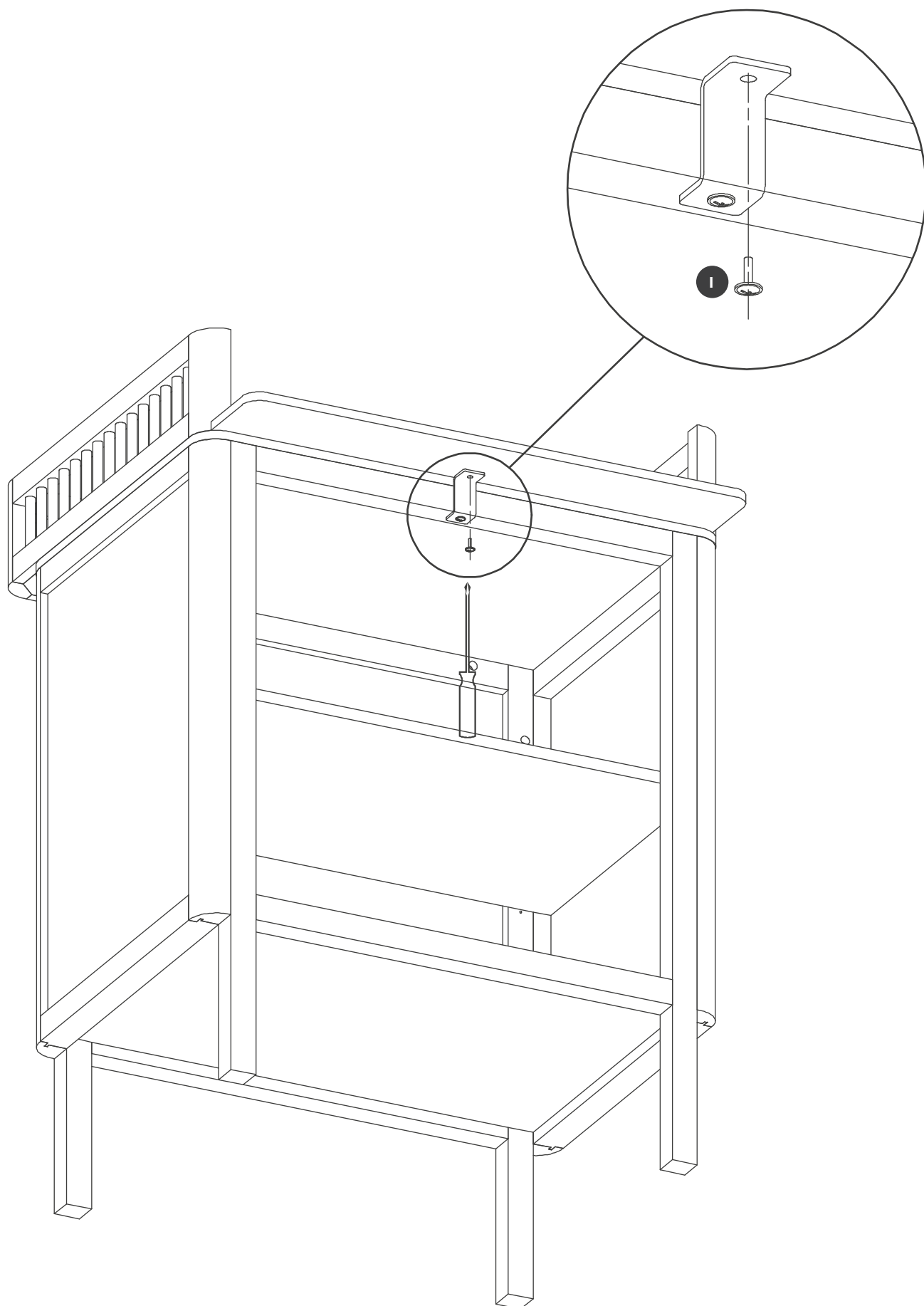

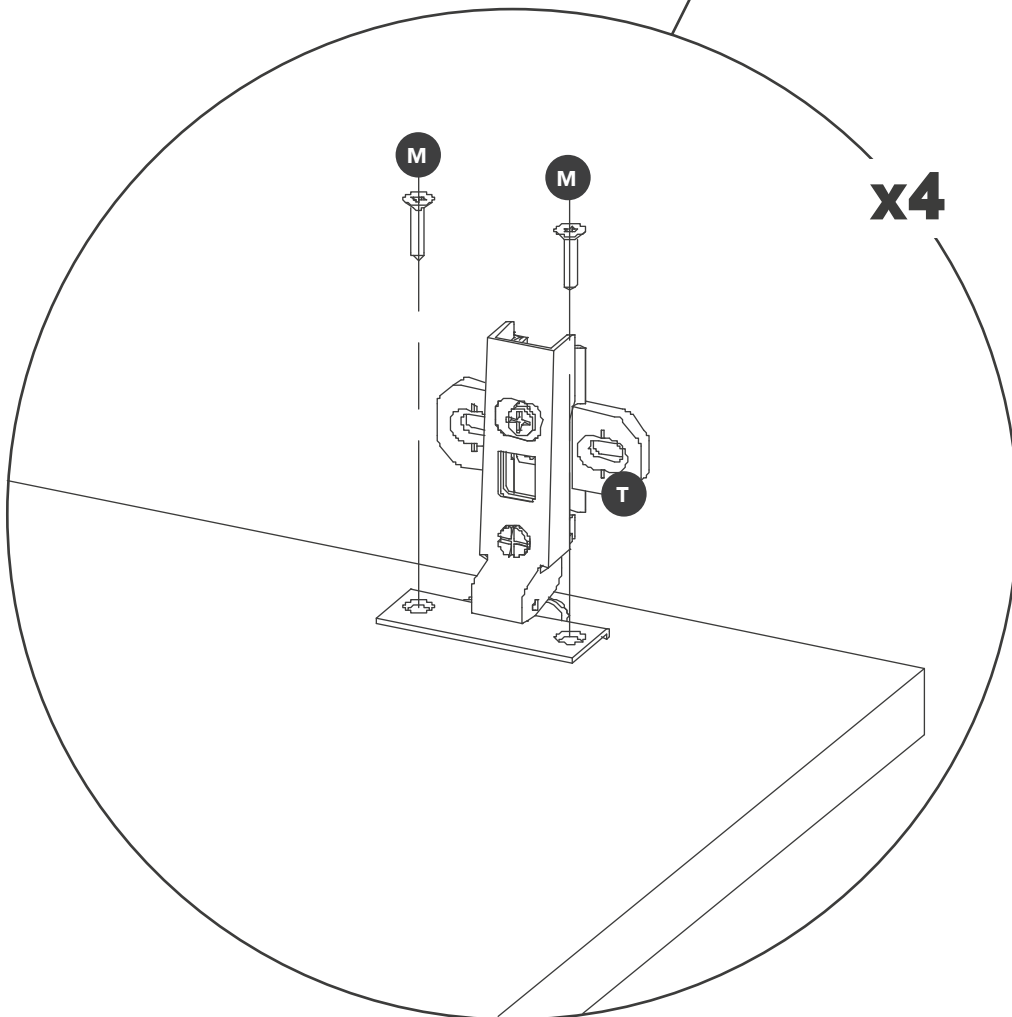
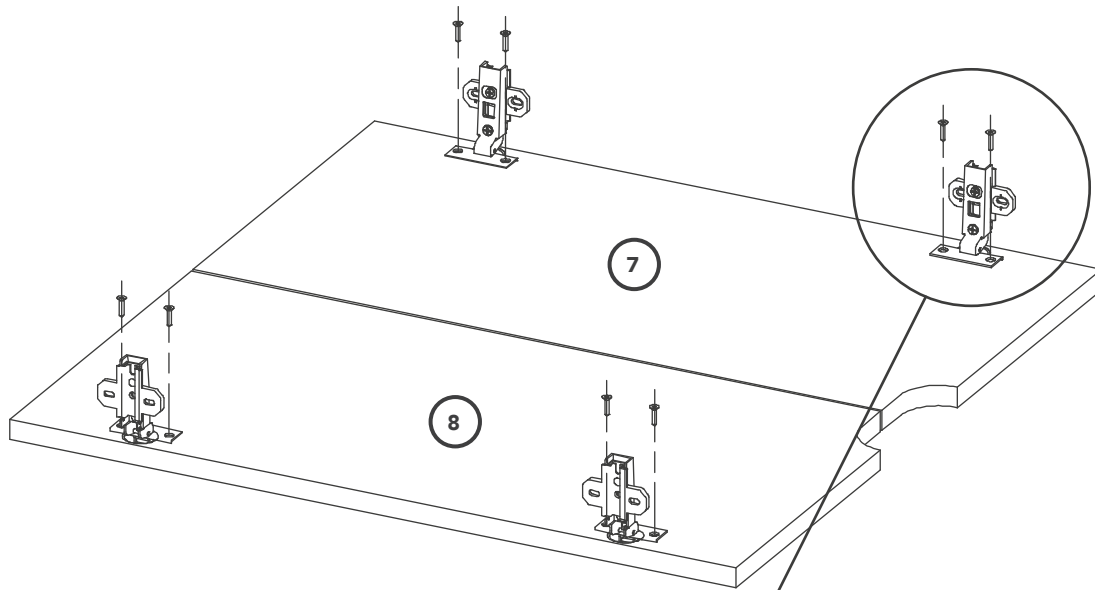

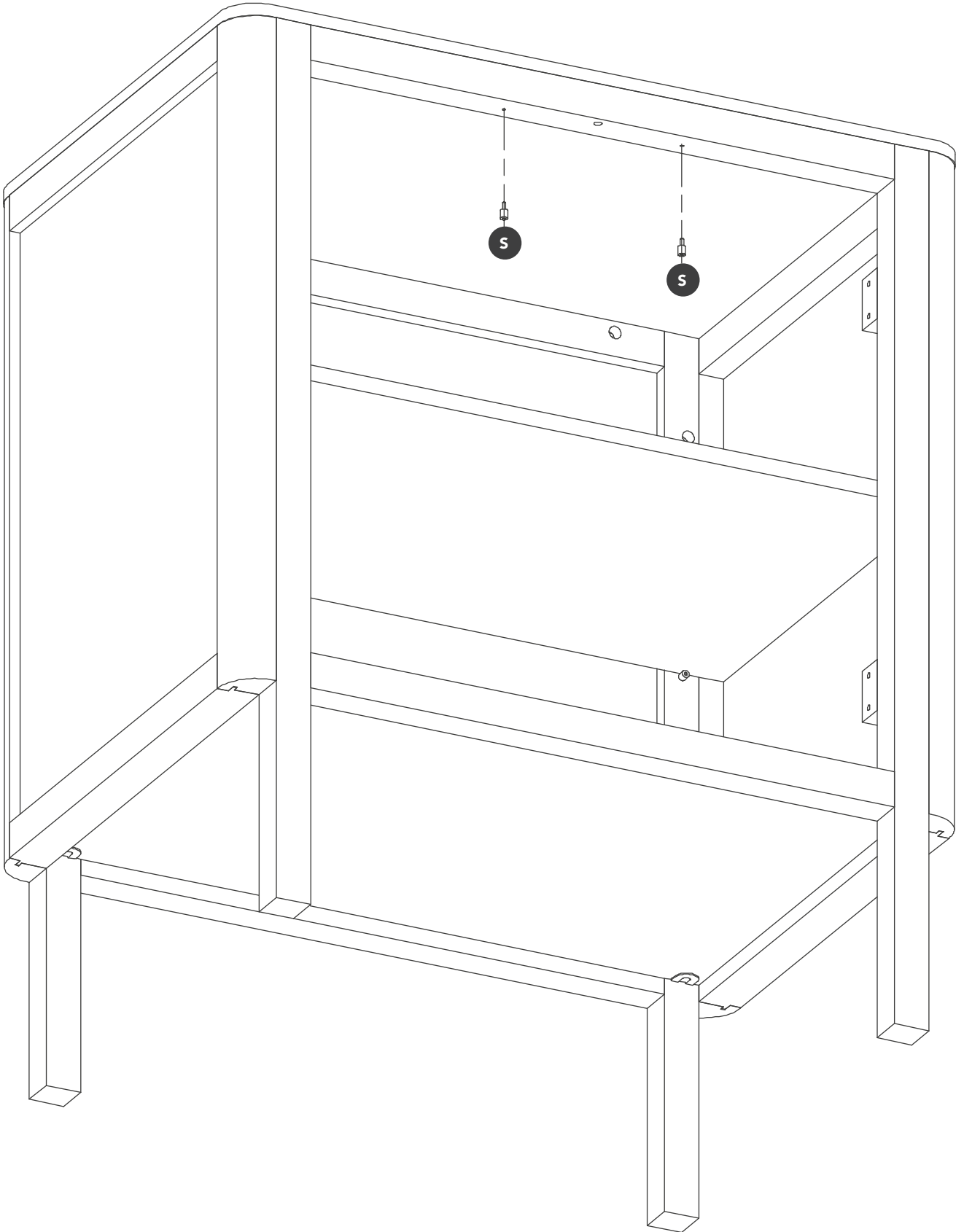

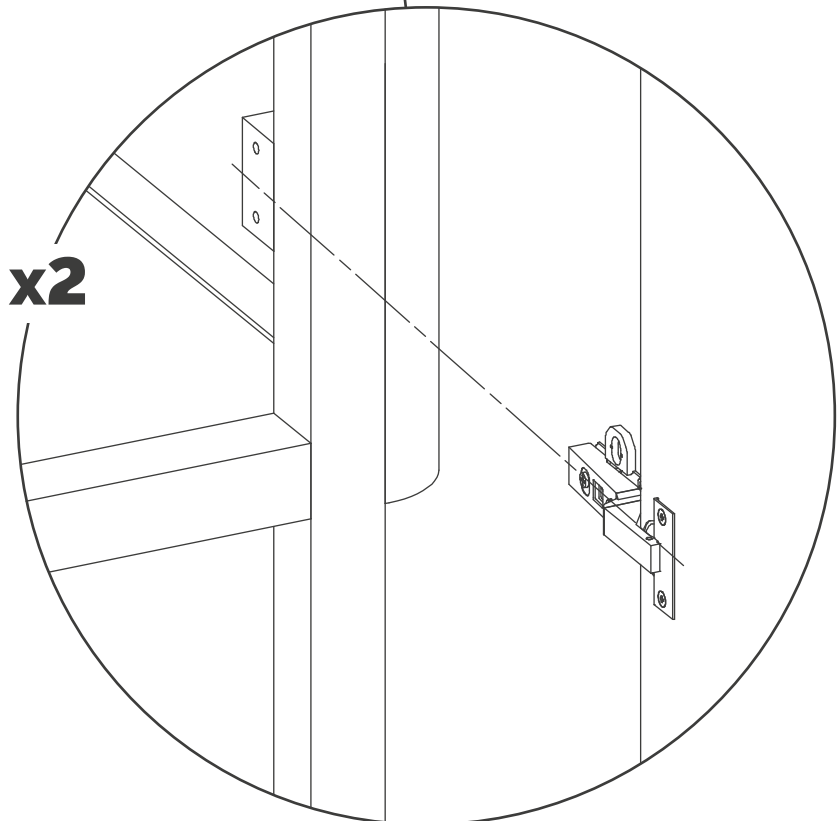
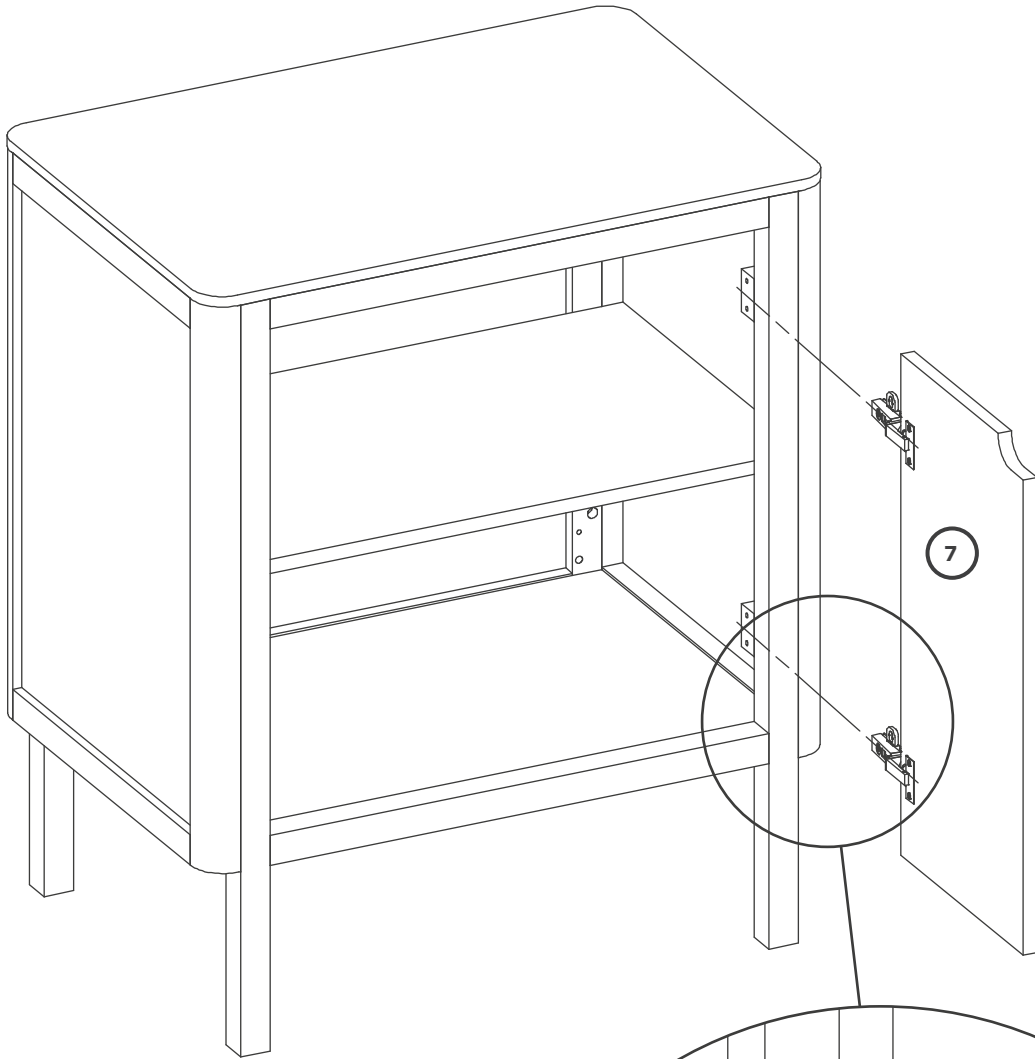

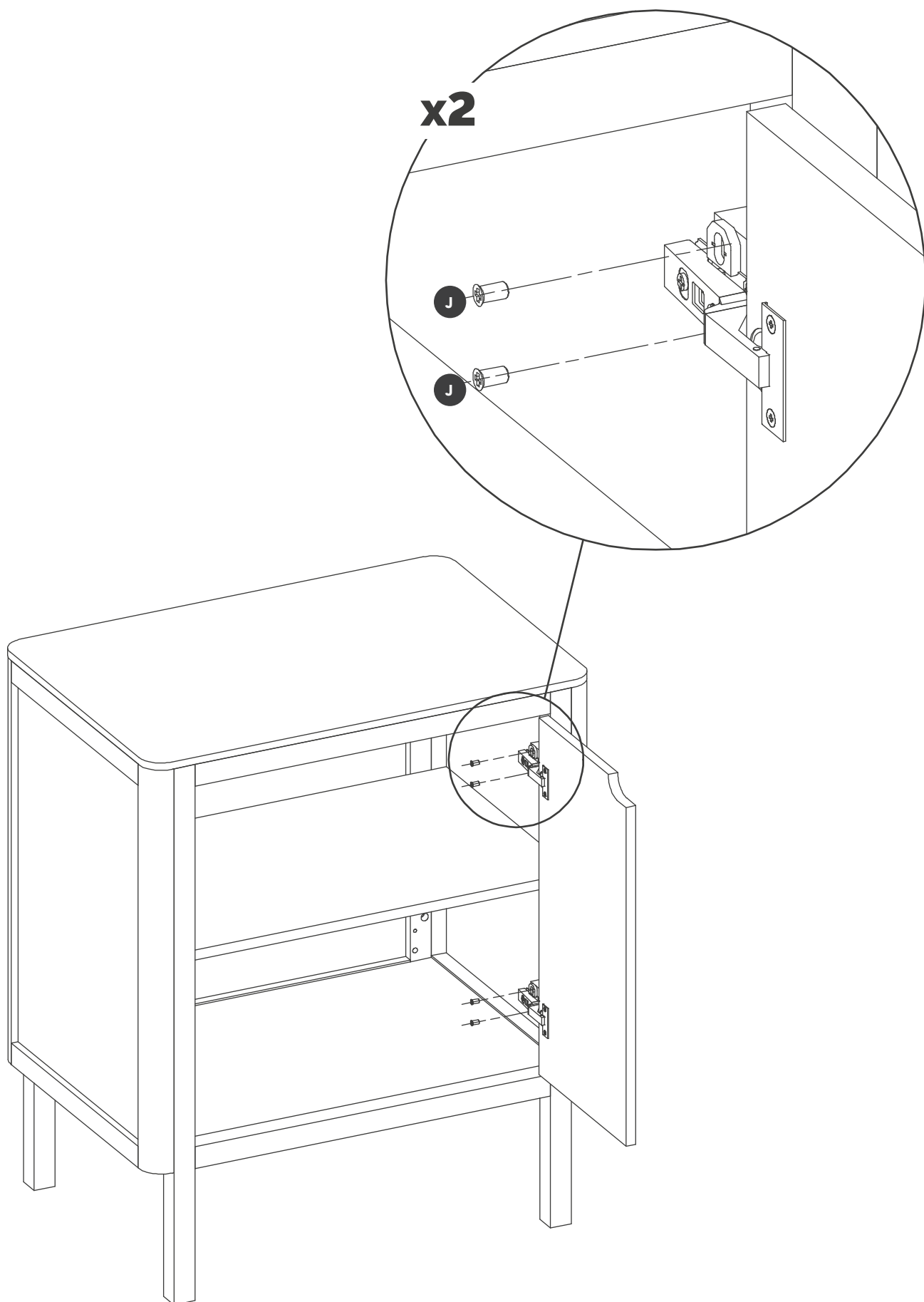

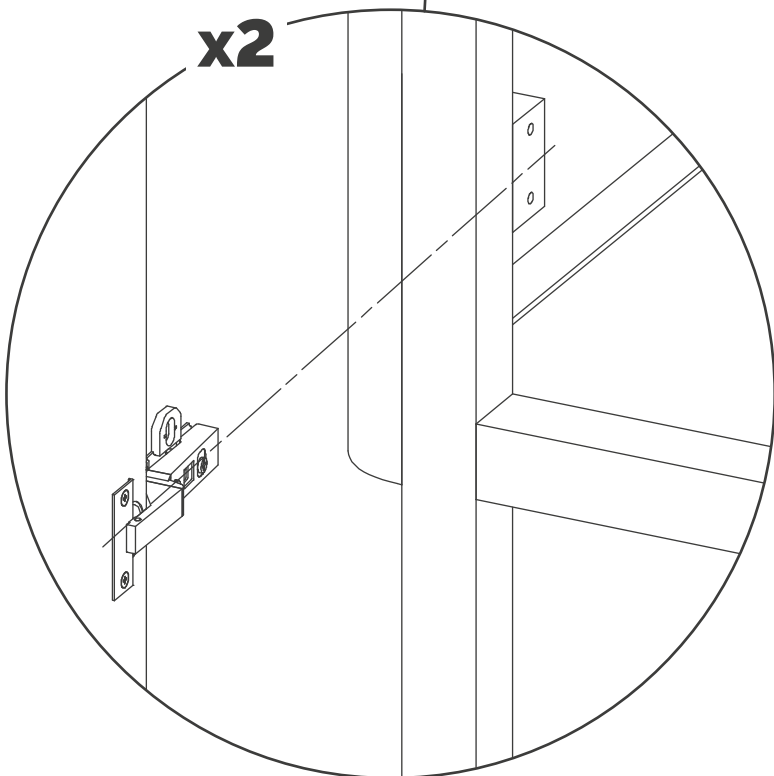
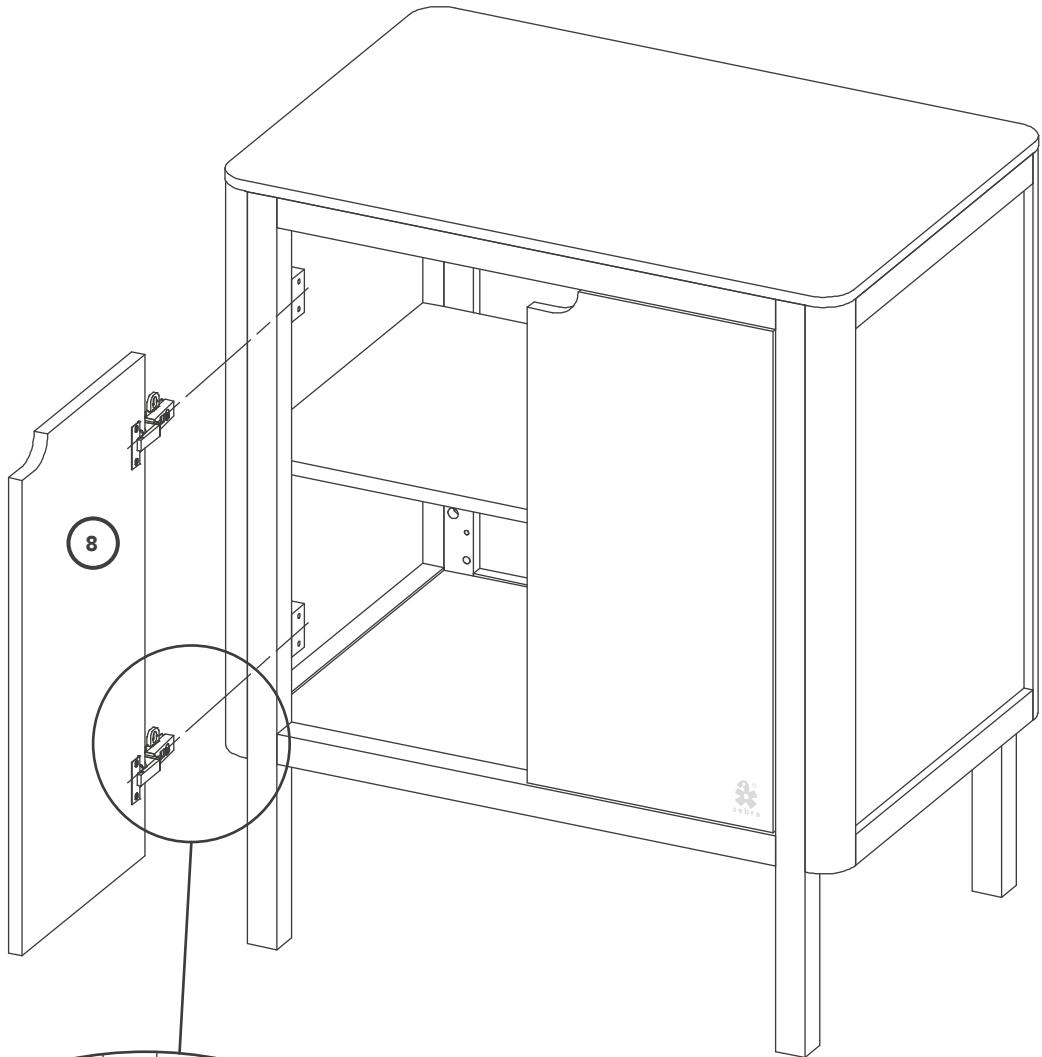

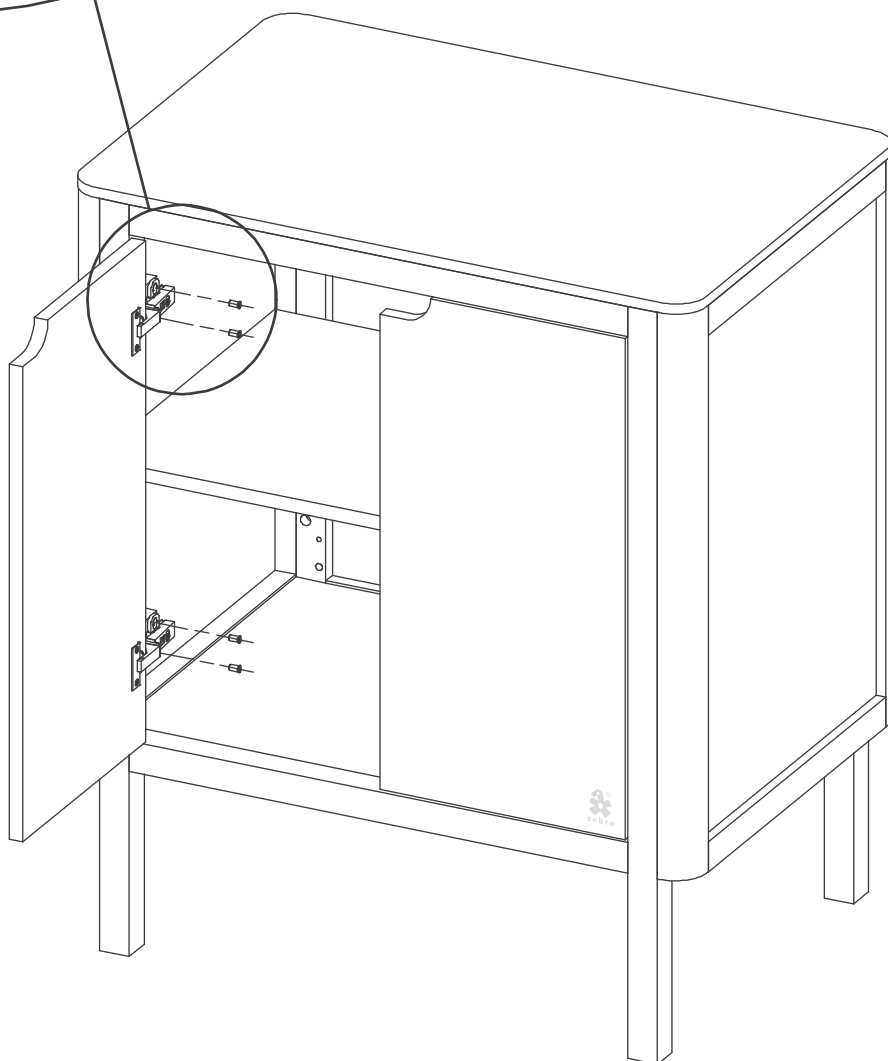
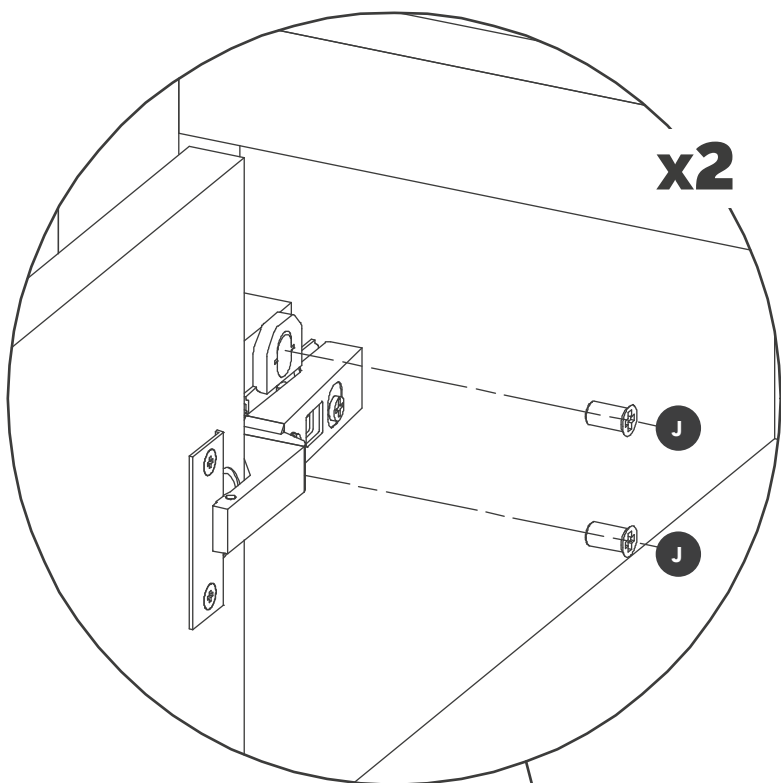

UK



WARNING

Never leave an infant on the changing table without adult supervision. Never turn your gaze away from the child while he or she is on the changing table.

Be aware of the risks associated with open flames and other sources of intense heat, such as electric heaters and gas ovens, near the product. Always place the product on a firm, level floor.

Do not place small objects, toxic substances, hot objects, etc. in the vicinity of the product where your baby can reach them, as they can cause choking, poisoning or other injuries. Do not leave anything on the product and do not place the product close to another product which could pose a risk of suffocation or strangulation, such as blind or curtain cords, etc.

Do not use the product if one of the parts is broken, torn or missing. Use only spare parts approved by Sebra.

Screws and bolts should be regularly tightened as they may loosen during product use.

The changing table is designed for changing 0-12 month-old babies with a maximum weight of 11 kg.

Sebra changing table meets the safety requirements for child care products EN 12221-1:2008 + A1:2013 – including changing tables for private use.

All surfaces and paint meet the following regulations: EN 71-3 and REACH.

CHANGING PILLOW

Use only changing pillows without bumpers as the changing table is designed with effective barriers. The changing pillow should be placed in the middle of the changing table to make distance to the edge. We recommend to use a changing pillow with a non-slip bottom.

DK



ADVARSEL

Efterlad aldrig et spædbarn på puslebordet uden opsyn fra voksne. Vend aldrig blikket væk fra barnet, mens det ligger på puslebordet.

Vær opmærksom på risikoen forbundet med åben ild og andre kraftige varmekilder, fx elektriske varmeovne og gasovne, i nærheden af produktet. Placer altid produktet på et stabilt, plant gulv.

Placer ikke små genstande, giftige stoffer, varme genstande osv. i nærheden af produktet, hvor din baby kan nå dem, da de kan forårsage kvælning, forgiftning eller andre skader. Efterlad ikke noget på produktet og placer ikke produktet tæt på et andet produkt, som kan udgøre en fare for kvælning eller strangulering fx persienne- eller gardinsnore etc.

Brug ikke produktet, hvis en af delene er knækket, revet itu eller mangler. Brug altid kun reservedele, der er godkendt af Sebra.

Skruer og bolte bør jævnligt efterspændes, da de kan løse sig ved brug af produktet.

Puslebordet er beregnet til at pusle 0-12 måneders gamle babyer med en maksimalvægt på 11 kg.

Sebra puslebordet opfylder sikkerhedskravene til børneomsorgsprodukter i EN 12221-1:2008 + A1:2013 – herunder pusleborde til privat brug.

Alle flader og maling lever op til følgende regulativer: EN 71-3 og REACH.

PUSLEPUDE

Brug kun puslepude/liggeunderlag uden barrierer, da puslebordet er konstrueret med effektive barrierer. Puslepuden/liggeunderlaget bør placeres midt på puslebordet, således at der er god afstand til puslebordets kanter og gerne med et skridsikkert underlag.

DE



WARNUNG

Lassen Sie einen Säugling oder ein Kleinkind niemals ohne Aufsicht von Erwachsenen alleine auf dem Wickeltisch. Behalten Sie das Kind stets im Blick, während es auf dem Wickeltisch liegt.

Achten Sie auf Gefahrenquellen wie offene Flammen oder andere starke Hitzequellen, wie Elektroheizungen oder Gasöfen, in der Nähe des Produkts. Platzieren Sie das Produkt auf einem festen, ebenen Boden.

Stellen Sie keine kleinen Gegenstände, giftigen Substanzen oder heißen Gegenstände usw. in die Nähe des Produkts, wo das Baby sie erreichen kann, da sie Erstickung, Vergiftungen oder Verletzungen verursachen können. Hinterlassen Sie nichts auf dem Produkt und platzieren Sie das Produkt nicht in der Nähe eines Produkts, das eine Erstickungs- oder Strangulations-Gefahr birgt, wie z. B. Jalousie- oder Vorhangschnüre.

Das Produkt darf nicht verwendet werden, wenn Teile fehlen oder wenn Teile abgebrochen oder eingegrissen sind. Verwenden Sie nur Ersatzteile, die von Sebra empfohlen werden.

Schrauben und Bolzen sollten regelmäßig nachgezogen werden, da sie sich durch den Gebrauch des Produktes lösen können.

Der Wickeltisch ist für Babys im Alter von 0 bis 12 Monaten mit einem Gewicht von maximal 11 kg konzipiert.

Der Sebra Wickeltisch erfüllt die geltenden Sicherheitsanforderungen für Produkte für Säuglinge und Kleinkinder entsprechend den Bestimmungen in EN 12221-1:2008 + A1:2013 – einschließlich der Bestimmungen für Wickeleinrichtungen für den privaten Gebrauch.

Alle Oberflächen und Farben erfüllen die folgenden Verordnungen: EN 71-3 und REACH.

WICKELAUFLAGE

Verwenden Sie ausschließlich Wickelauflagen/Wickelmatten ohne erhöhte Kanten, da der Wickeltisch bereits mit einer wirksamen Sicherheitskante ausgestattet ist. Die Wickelaufgabe/die Wickelmatte sollte in der Mitte des Wickeltisches platziert werden, sodass eine gute Entfernung zu dem Kanten des Wickeltisches besteht, und sie sollte am besten zusammen mit einer rutschfesten Unterlage verwendet werden.

FR



AVERTISSEMENT

Ne jamais laisser un enfant sur la table à langer sans surveillance d'un adulte. Ne jamais détourner le regard de l'enfant quand il est sur la table à langer.

Soyez conscient des risques associés aux flammes et aux autres sources de chaleur intense, comme les radiateurs électriques ou à gaz près du produit. Toujours installer le produit sur un sol ferme et de niveau.

Ne pas placer de petits objets, des substances toxiques, des objets chauds, etc. à proximité du produit où votre bébé peut les atteindre, car ils peuvent provoquer une suffocation, un empoisonnement ou d'autres blessures. Ne laisser aucun objet sur ce produit et ne pas le positionner près d'un autre produit qui pourrait poser un risque de suffocation ou d'étranglement, comme les cordons des stores ou des rideaux, etc.

Ne pas utiliser le produit si l'une des parties est cassée, abîmée ou manquante. Utiliser uniquement des pièces de rechange approuvées par Sebra.

Les vis et les boulons doivent être serrés régulièrement car ils peuvent se desserrer pendant l'utilisation du produit.

La table à langer est conçue pour changer les bébés âgés de 0 à 12 mois et pesant 11 kg maximum.

La table à langer Sebra répond aux normes de sécurité des articles de puériculture EN 12221-1 : 2008 + A1 : 2013 – incluant les tables à langer à usage privé.

Toutes les peintures et autres surfaces respectent la norme suivante : EN 71-3 et REACH.

MATELAS À LANGER

N'utiliser que des matelas à langer/ serviette à langer sans rebord car la table à langer est conçue avec des barrières efficaces. Le matelas/serviette à langer doit être placé au milieu de la table à langer de façon à ce qu'il y ait une bonne distance par rapport aux bords de la table à langer. Nous vous recommandons d'utiliser un matelas/serviette à langer recouvert d'une surface antidérapante.



ADVERTENCIA

Nunca deje a un bebé en el cambiador sin la supervisión de adultos. Nunca desvíe la mirada del niño mientras se encuentre en el cambiador.

Tenga presente los riesgos que conlleva el fuego u otras fuentes de calor intenso, tales como calentadores eléctricos y hornos de gas, cerca del producto. Coloque siempre el producto en un suelo firme y nivelado.

No coloque objetos pequeños, sustancias tóxicas, objetos calientes, etc., en las proximidades del producto donde su bebé puede alcanzarlos, ya que pueden causar asfixia, envenenamiento u otras lesiones. No deje nada sobre el producto y no coloque el producto cerca de otro artículo que pueda suponer un riesgo de asfixia o estrangulamiento, por ejemplo cordones de las persianas o cortinas, etcétera.

No utilice el producto si una de las partes está partida, rota, hecha pedazos o falta. Utilice únicamente piezas de repuesto aprobadas por Sebra.

Los tornillos y las tuercas deben apretarse con regularidad, ya que pueden aflojarse durante el uso del producto.

El cambiador está diseñado para cambiar a bebés de entre 0 y 12 meses de edad, con un peso máximo de 11 kg.

El cambiador Sebra cumple con los requisitos de seguridad de los productos para el cuidado de los niños EN 12221-1:2008 + A1:2013; entre los que se incluyen los cambiadores para uso privado.

Todas las superficies y la pintura cumplen con las siguientes normas: EN 71-3 y REACH.

COJÍN DE LACTANCIA

Use solamente el cojín o la esterilla sin barreras, ya que el cambiador está diseñado con barreras efectivas. El cojín de lactancia o la esterilla deben colocarse en el centro del cambiador, de manera que haya una buena distancia hasta los bordes de este, así como una superficie antideslizante.



AVVERTENZE

Non lasciare mai il bambino sul fasciatoio, senza la supervisione di un adulto. Non distogliere mai lo sguardo dal bambino mentre si trova sul fasciatoio.

Fiamme libere e altre fonti di calore intenso, come riscaldatori elettrici e forni a gas, in prossimità del prodotto comportano dei rischi. Collocare sempre il prodotto su una superficie stabile e piana.

Non posizionare piccoli oggetti, sostanze tossiche, oggetti caldi, ecc. in prossimità del fasciatoio e alla portata del bambino, per evitare il rischio di soffocamento, avvelenamento o altre lesioni. Non lasciare nulla sul fasciatoio e non collocarlo vicino a oggetti che potrebbero determinare il rischio di soffocamento o strangolamento, come corde di tapparelle o di tende, ecc.

Non utilizzare il prodotto in caso di parti rotte, danneggiate o mancanti. Utilizzare esclusivamente parti di ricambio approvate da Sebra.

Viti e bulloni devono essere serrati regolarmente, in quanto possono allentarsi durante l'uso del prodotto.

Il fasciatoio è progettato per cambiare bambini da 0 a 12 mesi di età, con peso massimo di 11 kg.

Il fasciatoio Sebra è conforme ai requisiti di sicurezza per i prodotti per la cura del bambino EN 12221-1: 2008 + A1: 2013 - compresi fasciatoio per uso privato.

Tutte le superfici e le vernici sono conformi alle seguenti norme: EN 71-3 e REACH.

MATERASSINO PER IL FASCIATOIO

Utilizzare solo materassini senza bordi rialzati, poiché il fasciatoio è dotato di efficaci barriere protettive. Il materassino deve essere collocato al centro del fasciatoio, in modo da assicurare una distanza ottimale dai bordi. Si consiglia di utilizzare un materassino con superficie antiscivolo.



WAARSCHUWING

Laat nooit een kind op de commode achter zonder toezicht van volwassenen. Wend uw blik nooit van het kind af, terwijl het op de commode ligt.

Let op de risico's van open vuur en andere bronnen van intense hitte, zoals elektrische kachels en gasovens, in de buurt van het product. Plaats het product altijd op een stevige, vlakke vloer.

Laat kleine voorwerpen, giftige stoffen, hete voorwerpen enz. niet achter in de nabijheid van het product onder bereik van uw kind, omdat ze verstikking, vergiftiging of andere verwondingen kunnen veroorzaken. Laat niets op het product achter en plaats het product niet dicht bij een ander product, dat een gevaar voor verstikking of wurging zou kunnen opleveren, bijvoorbeeld luxaflex- of gordijnkoorden.

Gebruik het product niet als een van de onderdelen is gebroken, gescheurd of ontbreekt. Gebruik altijd alleen onderdelen die door Sebra zijn goedgekeurd.

Bouten en moeren moeten regelmatig worden aangedraaid, omdat ze kunnen losraken tijdens gebruik van het product.

De commode is ontworpen om een 0-12 maanden oude baby met een maximum gewicht van 11 kg te verzorgen.

De Sebra commode voldoet aan de veiligheidseisen voor kindzorgproducten EN 12221-1: 2008 + A1: 2013 - waaronder commodes voor privégebruik.

Alle oppervlakken en verf voldoen aan de volgende regelgeving: EN 71-3 en REACH.

AANKLEEDKUSSEN

Gebruik het aankleedkussen/ligkussen zonder barrière alleen wanneer de commode is ontworpen met effectieve barrières. Het aankleed-/ligkussen moet in het midden van de commode worden geplaatst met voldoende afstand tot de randen van de commode en het liefst met een antislip-oppervlak.

PRODUCTION-/BATCH NO.

THE BATCH NUMBER IS PLACED THE FOLLOWING PLACES

**UNDERNEATH THE TOP BOARD
UNDERNEATH THE CHANGING TOP
UNDERNEATH ONE OF THE SHELVES
UNDERNEATH ONE OF THE DRAWERS**

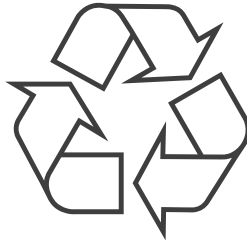

This assembly has been printed
on recycled paper

Get connected
@sebrainterior

